

TECHNICAL SPECIFICATION

FOR PREPARATION OF HOLDERS AND APPLICATION FORMS PRINTING



CARDS PRINT

Novoseljanski put 38d, 26000 Pancevo, Serbia

+381 11 41 41 540

info@cards-print.com | www.cards-print.com



THE PLASTIC CARD SPECIALISTS



www.cards-print.com

Content

1. MODELS & DIMENSIONS

1.1 HOLDERS

- 1.1.1 Model 01
- 1.1.2 Model 02
- 1.1.3 Model 03
- 1.1.4 Model 06
- 1.1.5 Model 10
- 1.1.6 Model 11
- 1.1.7 Model 12
- 1.1.8 Model 13
- 1.1.9 Model 14
- 1.1.10 Model 15
- 1.1.11 Model 16

1.2 APPLICATION FORMS

- 1.2.1 Model 01
- 1.2.2 Model 02
- 1.2.3 Model 03

2. INSTRUCTIONS FOR PRODUCING FILES

2.1 BASIC REQUIREMENTS

- 2.1.1 GENERAL
- 2.1.2 COLORS AND OBJECTS
- 2.1.3 PERSONALISATION

2.2 SETTING-UP THE CONTENT

- 2.2.1 BLEED
- 2.2.2 SAFE ZONE
- 2.2.3 PREPARATION OF BACKGROUND FOR PERFORATION

3. RECOMMENDATIONS

3.1 SOFTWARE

- 3.1.1 SOFTWARE SELECTION
- 3.1.2 EFFECTS AND FILTERS

3.2 COLORS

- 3.2.1 OVERPRINT

3.3 TYPES OF FILES

4. ADDITIONAL INFORMATION

4.1 SCOPE OF RESPONSIBILITY

4.2 CHECKLIST

CHAPTER 1

MODELS I DIMENSIONS

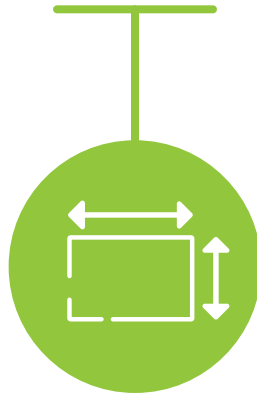

1.1 HOLDERS

1.1.1 Model 01

Outside and inside tools

LEGEND

Cutting ———
Creasing - - - - -
Perforation ·····

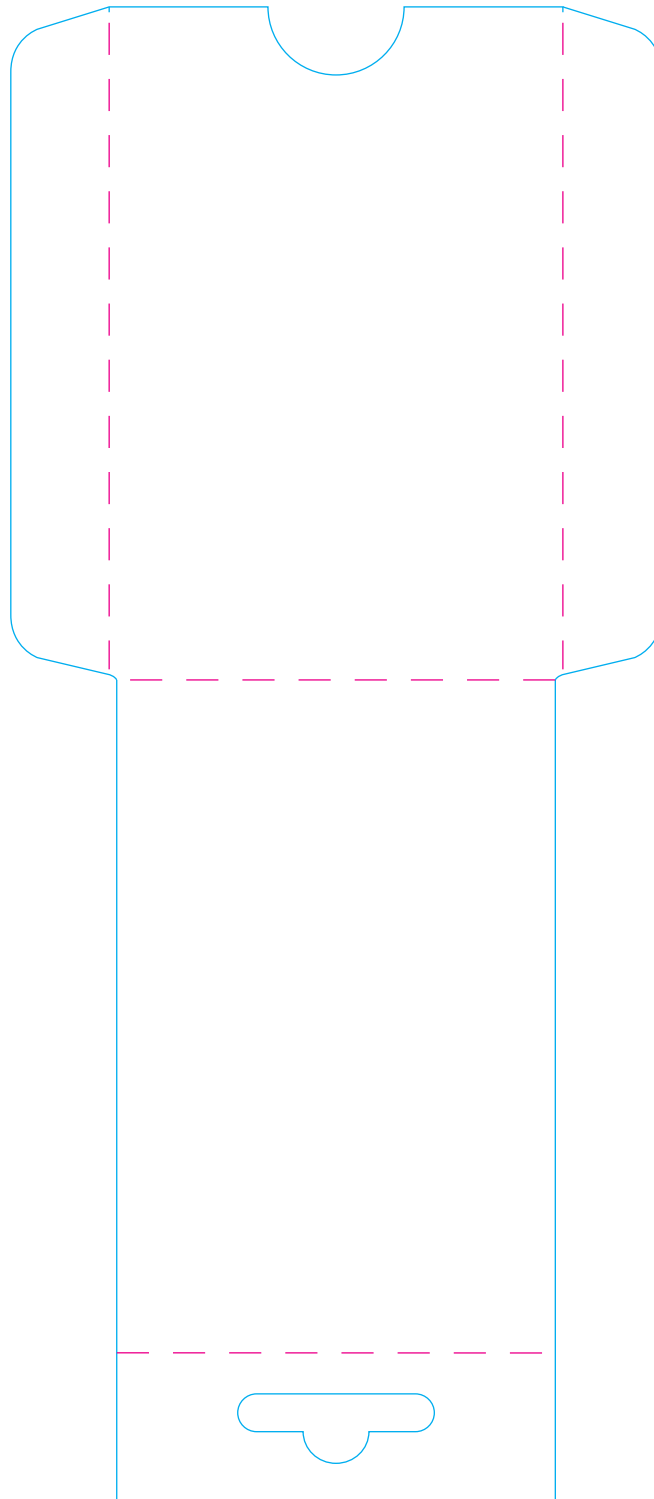

1.1 HOLDERS

1.1.1 Model 01



DIMENSION OF ASSEMBLED HOLDER		DIMENSION OF PREPARATION WITHOUT BLEED		Bleed
width	height	width	height	
62 mm	110 mm	143.5 mm	129.5 mm	It is necessary to leave 3 mm ON ALL SIDES

1.1 HOLDERS

1.1.2 Model 02

Outside tool

LEGEND

- Cutting ———
- Creasing - - - - -
- Perforation ·····

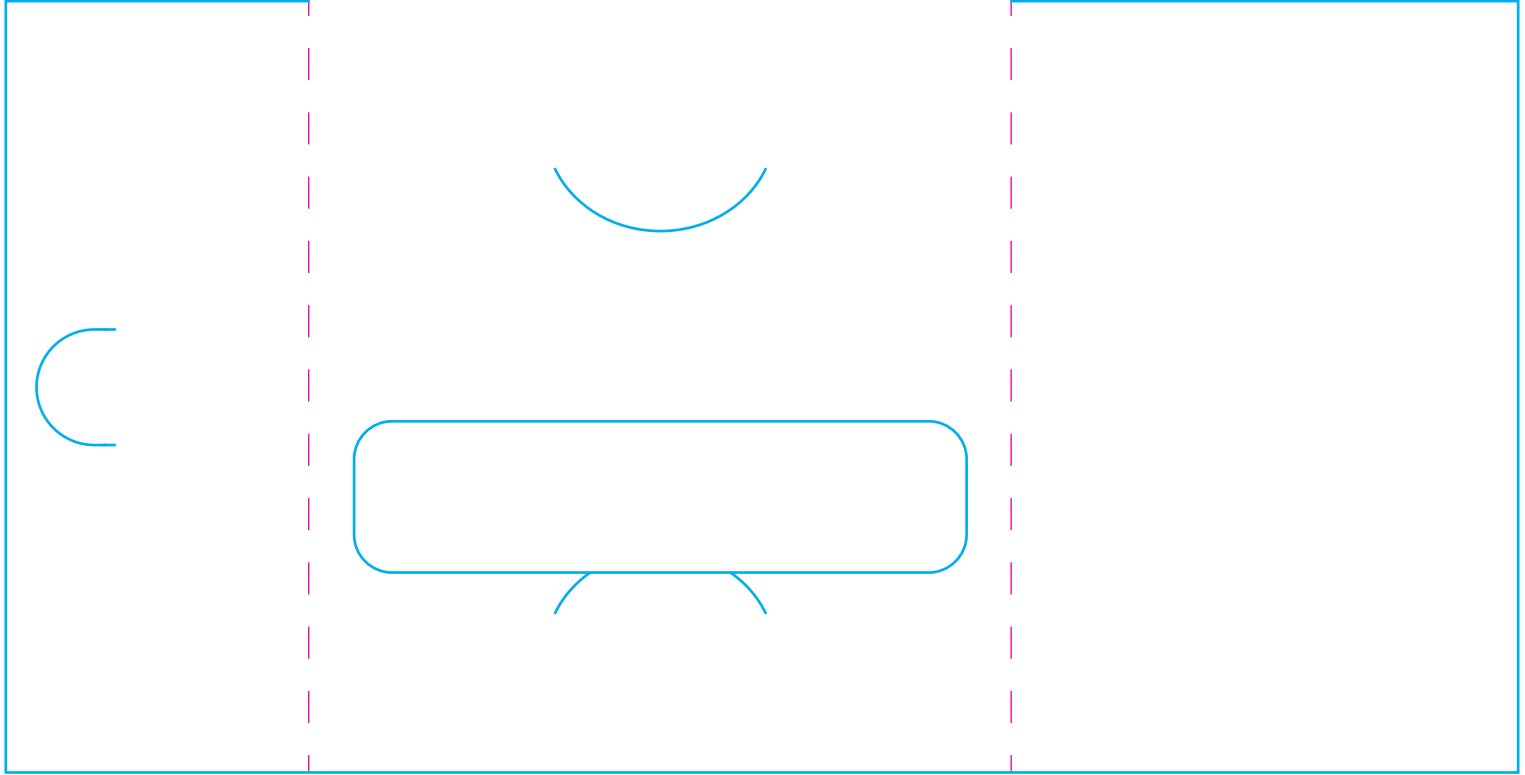

Inside tool

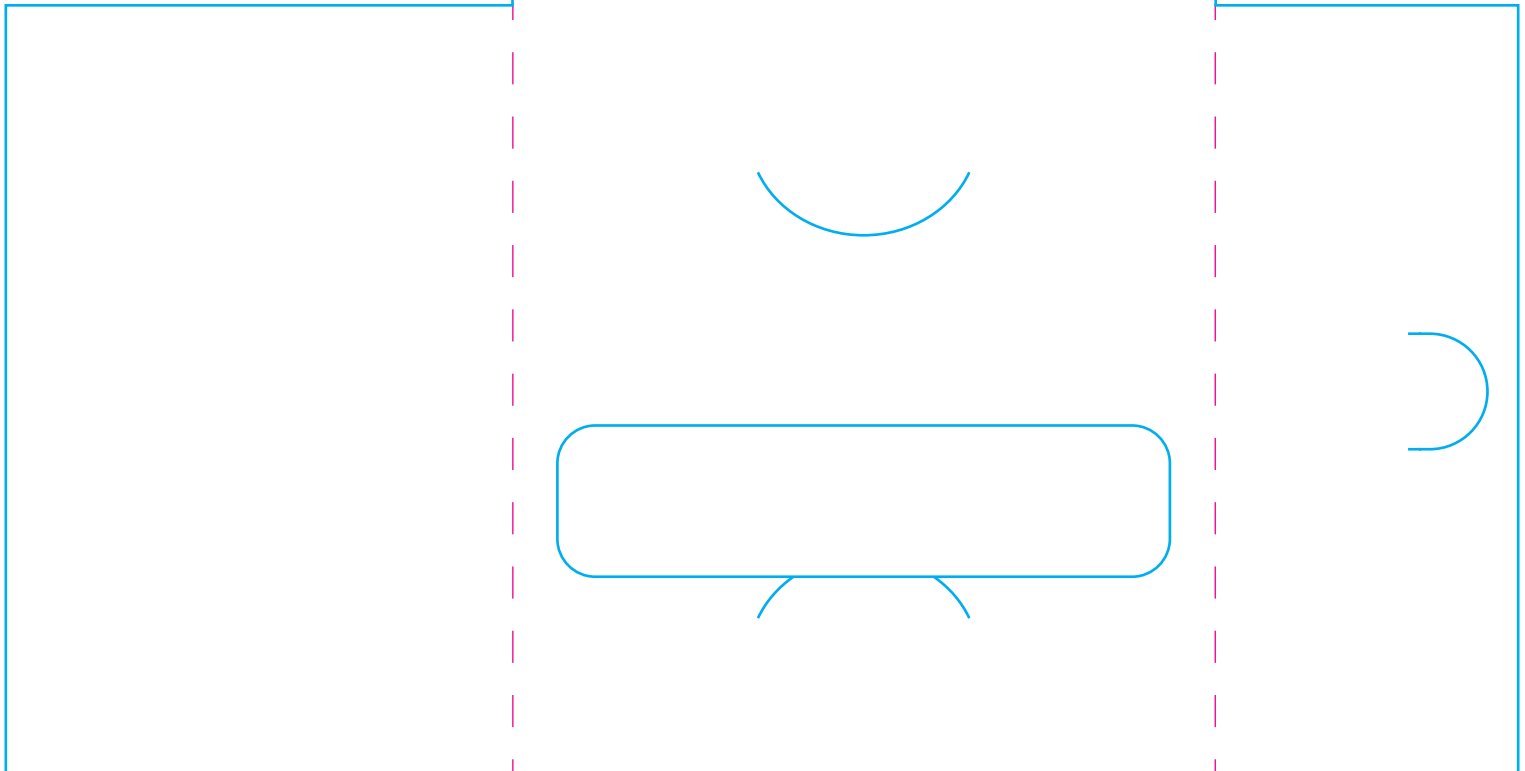

1.1 HOLDERS

1.1.2 Model 02



DIMENSION OF ASSEMBLED HOLDER		DIMENSION OF PREPARATION WITHOUT BLEED		Bleed
width	height	width	height	
93 mm	139 mm	200 mm	139 mm	It is necessary to leave 3 mm ON ALL SIDES

1.1 HOLDERS

1.1.3 Model 03

LEGEND

- Cutting ———
- Creasing - - - - -
- Perforation ·····

Outside tool

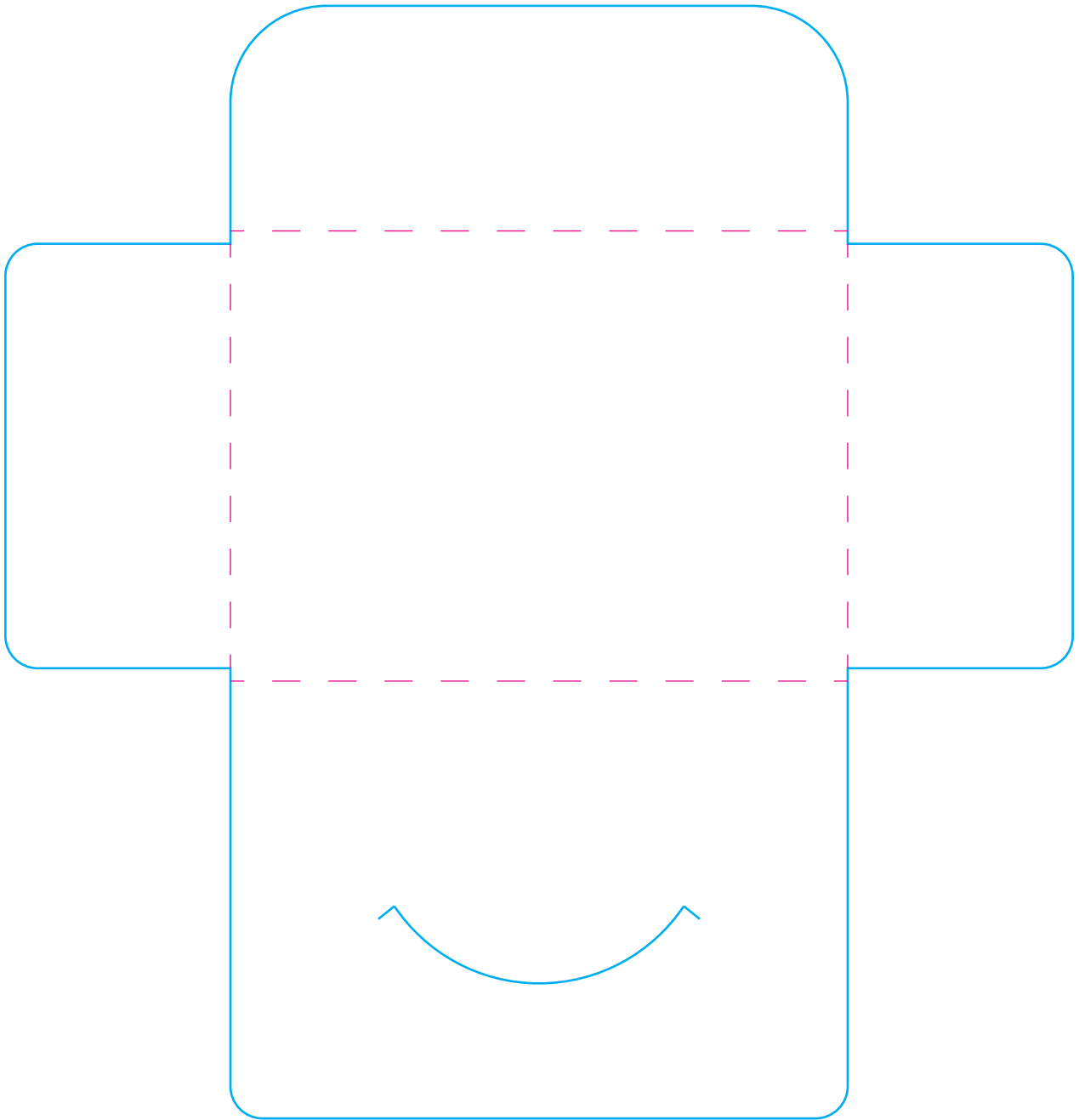

1.1 HOLDERS

1.1.3 Model 03

LEGEND

- Cutting ———
- Creasing - - - - -
- Perforation ·····

Inside tool

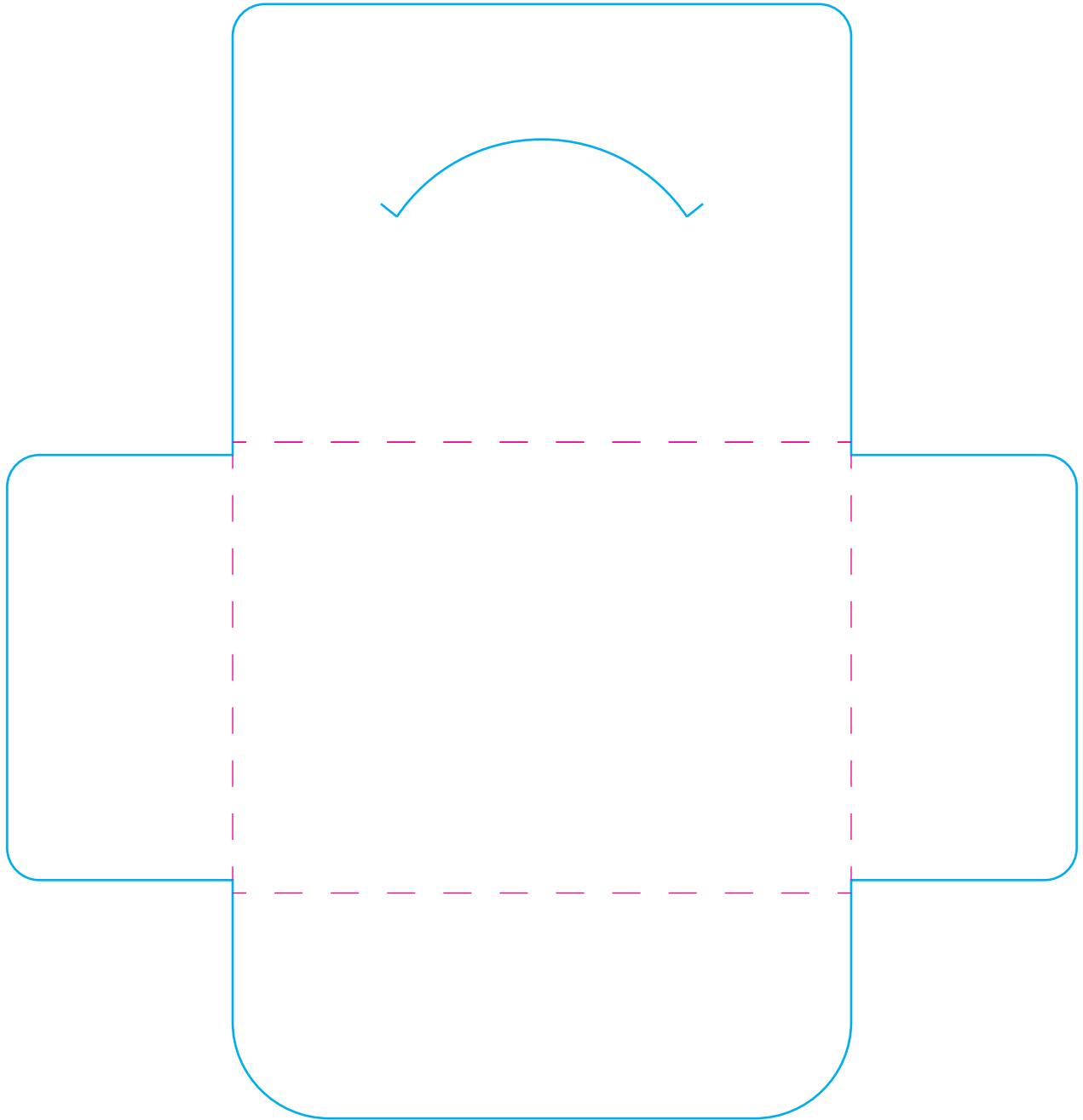

1.1 HOLDERS

1.1.3 Model 03



DIMENSION OF ASSEMBLED HOLDER		DIMENSION OF PREPARATION WITHOUT BLEED		Bleed
width	height	width	height	
96 mm	70 mm	172 mm	179 mm	It is necessary to leave 3 mm ON ALL SIDES

1.1 HOLDERS

1.1.4 Model 06

LEGEND

Cutting	
Creasing	
Perforation	

Outside tool

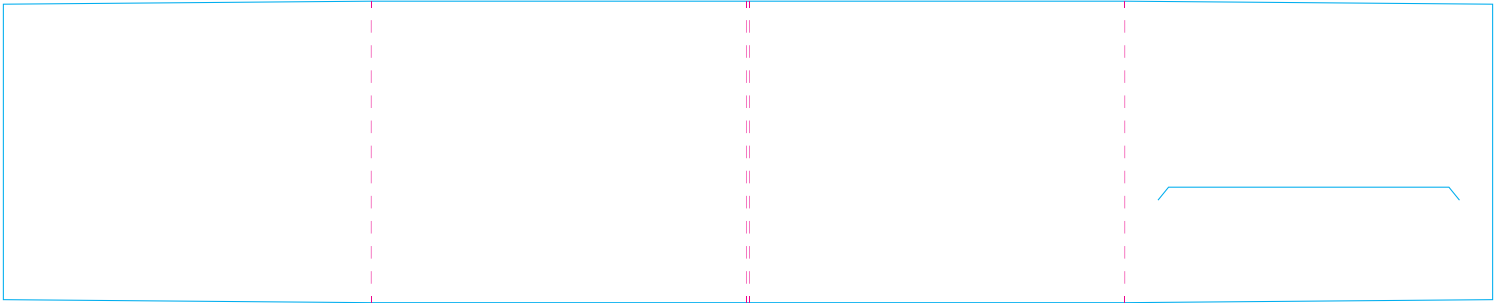

Inside tool

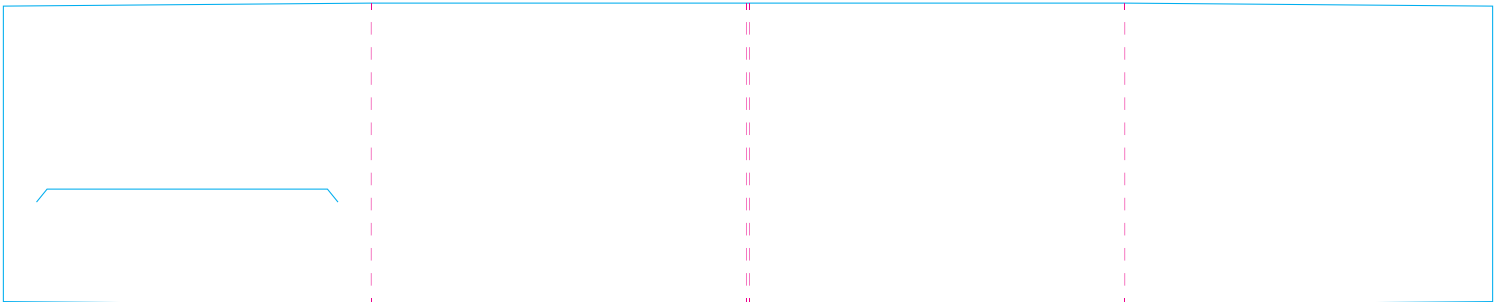

A Tool is not the right dimension, it has been zoomed out proportionally to fit A4 format. So, when you do the preparation, you need to zoom in the tool proportionally in accordance with the specification on the next page for Model 06.

1.1 HOLDERS

1.1.4 Model 06



DIMENSION OF ASSEMBLED HOLDER		DIMENSION OF PREPARATION WITHOUT BLEED		Bleed
width	height	width	height	
122 mm	99 mm	494 mm	98 mm	It is necessary to leave 3 mm ON ALL SIDES

1.1 HOLDERS

1.1.5 Model 10

LEGEND

Cutting ———
 Creasing - - - - -
 Perforation ·····

Outside tool

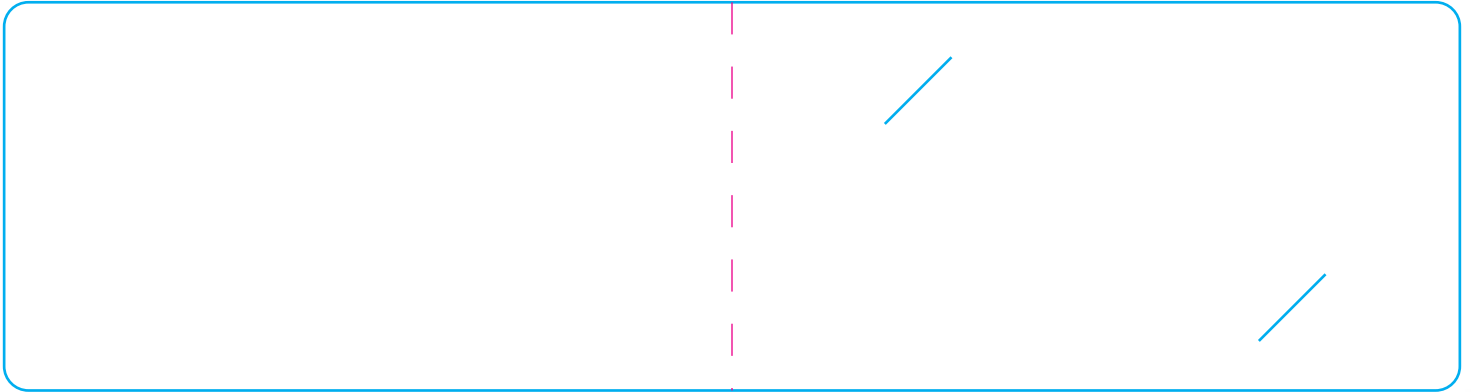

Inside tool

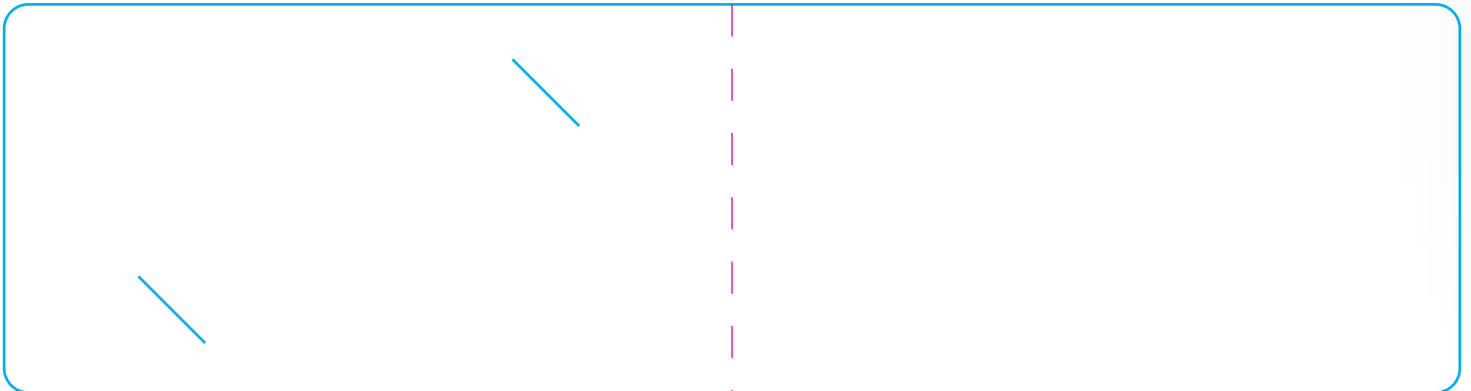

A Tool is not the right dimension, it has been zoomed out proportionally to fit A4 format. So, when you do the preparation, you need to zoom in the tool proportionally in accordance with the specification on the next page for Model 10.

1.1 HOLDERS

1.1.5 Model 10



DIMENSION OF ASSEMBLED HOLDER		DIMENSION OF PREPARATION WITHOUT BLEED		Bleed
width	height	width	height	
150 mm	80 mm	300 mm	90 mm	It is necessary to leave 3 mm ON ALL SIDES

1.1 HOLDERS

1.1.6 Model 11

Outside and inside tools

LEGEND

Cutting ———
Creasing - - - - -
Perforation ·····

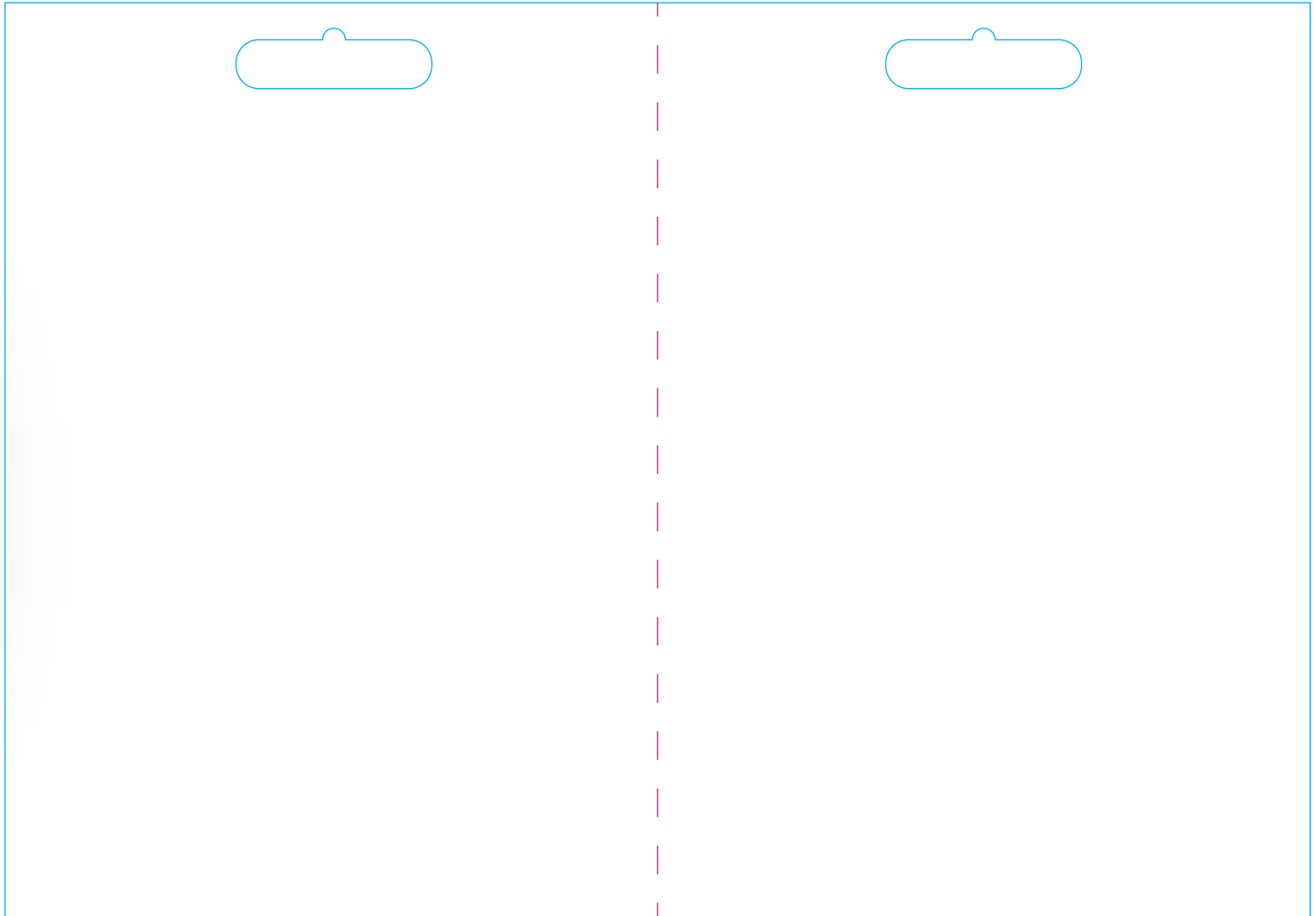

1.1 HOLDERS

1.1.6 Model 11

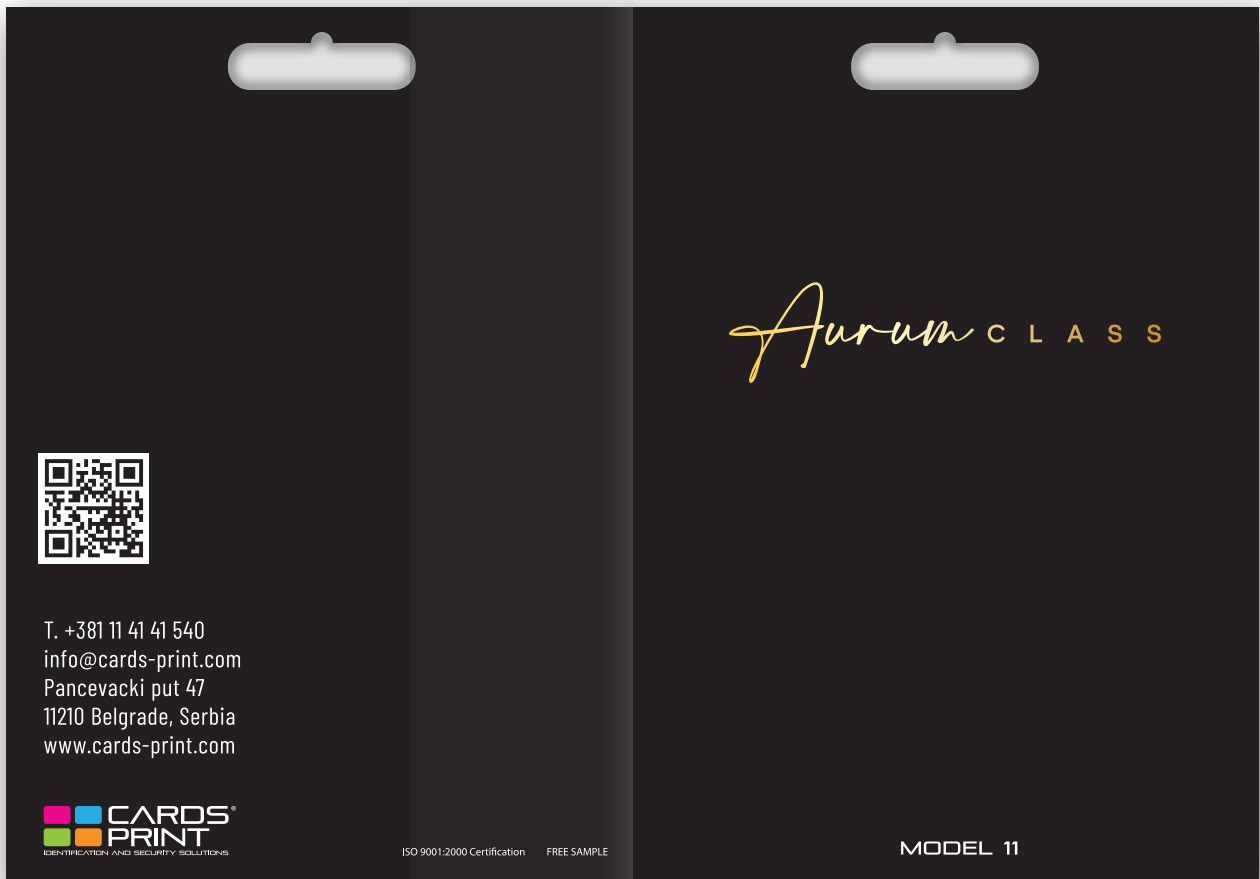

DIMENSION OF ASSEMBLED HOLDER		DIMENSION OF PREPARATION WITHOUT BLEED		Bleed
width	height	width	height	
100 mm	140 mm	200 mm	140 mm	It is necessary to leave 3 mm ON ALL SIDES

1.1 HOLDERS

1.1.7 Model 12

LEGEND

- Cutting 
- Creasing 
- Perforation 

Outside tool

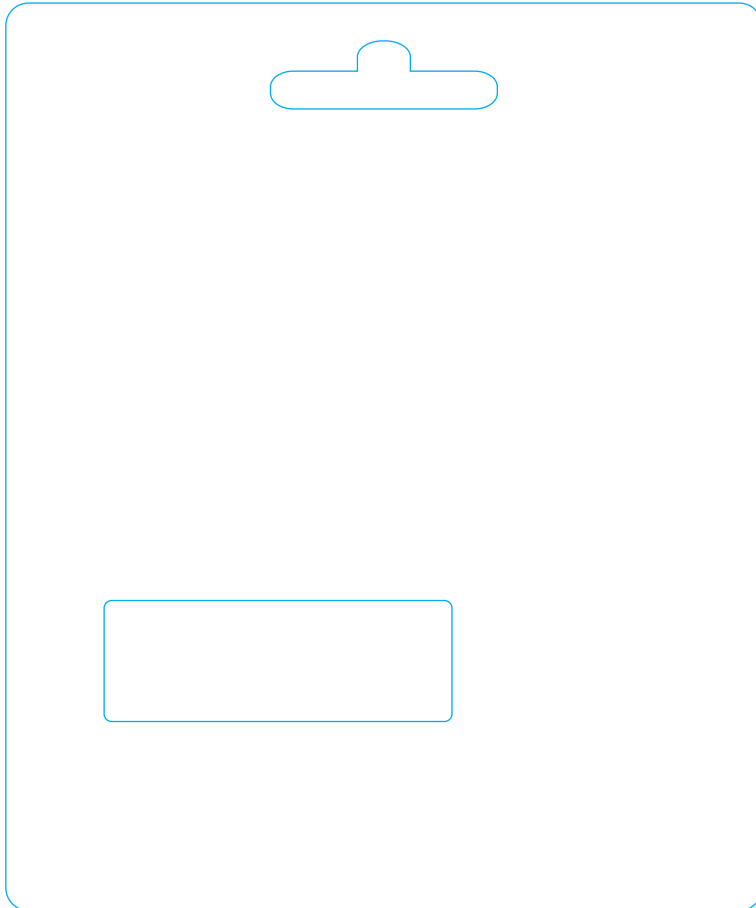

Inside tool

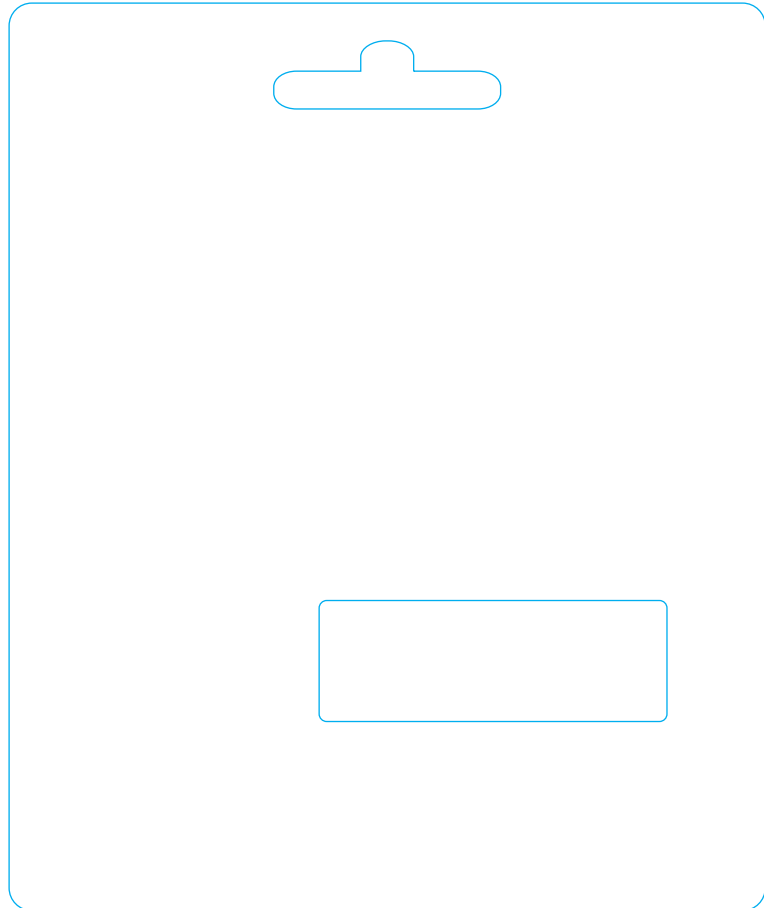

1.1 HOLDERS

1.1.7 Model 12

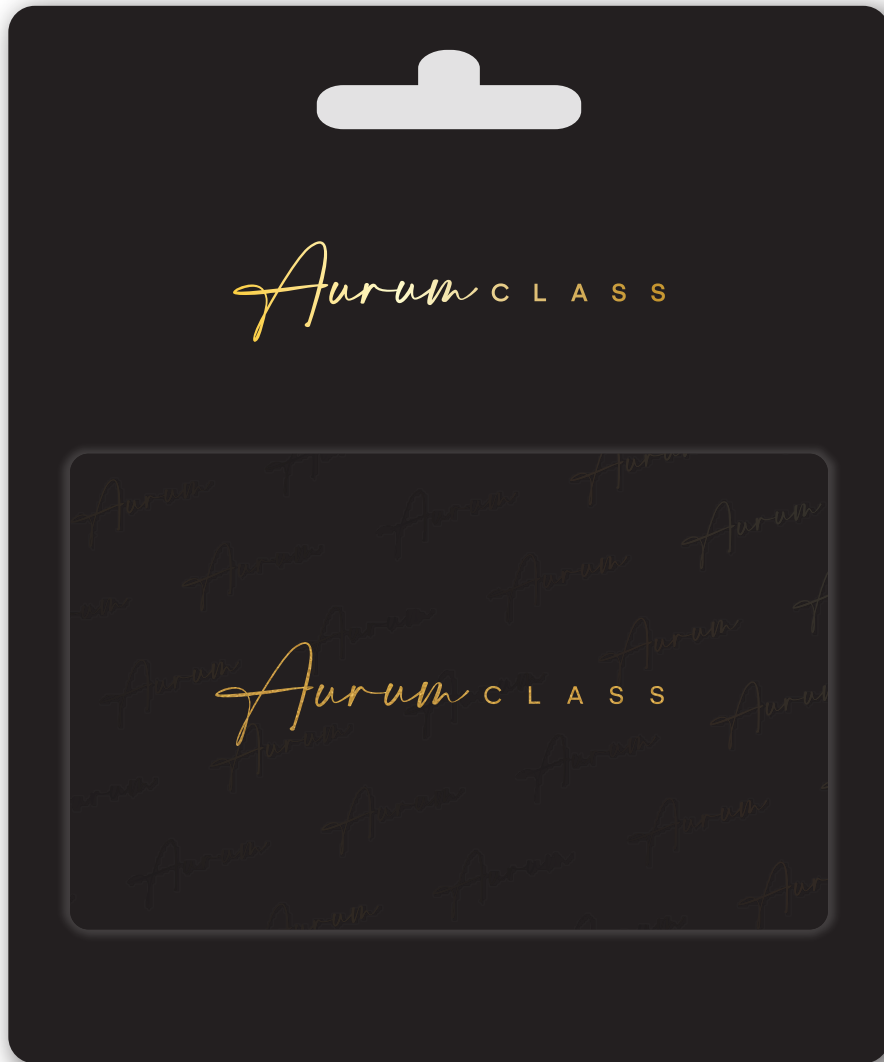

DIMENSION OF ASSEMBLED HOLDER		DIMENSION OF PREPARATION WITHOUT BLEED		Bleed
width	height	width	height	
100 mm	120 mm	100 mm	120 mm	It is necessary to leave 3 mm ON ALL SIDES

1.1 HOLDERS

1.1.8 Model 13

LEGEND

- Cutting ———
- Creasing - - - - -
- Perforation ·····

Outside tool

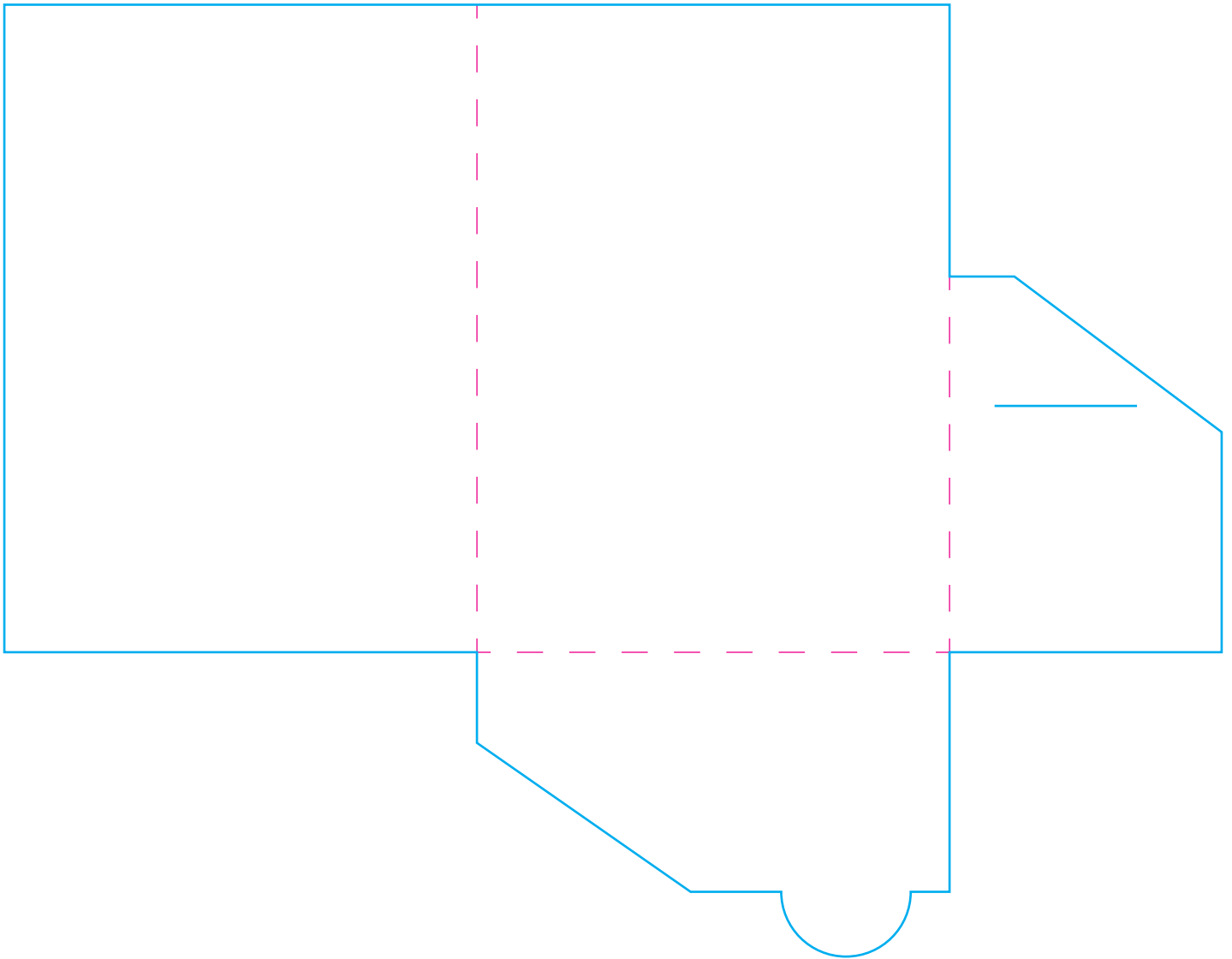

1.1 HOLDERS

1.1.8 Model 13

LEGEND

- Cutting ———
- Creasing - - - - -
- Perforation ·····

Inside tool

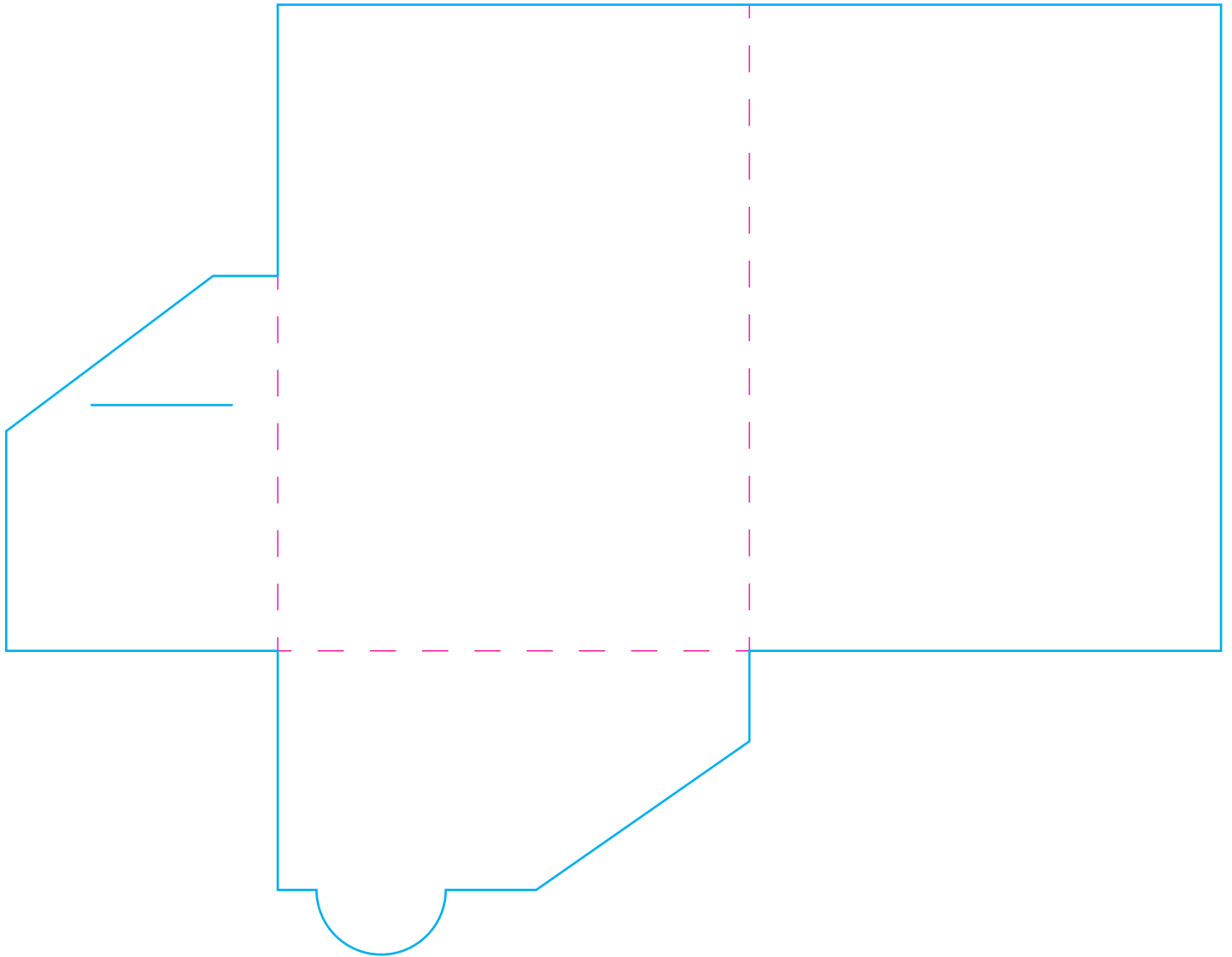

1.1 HOLDERS

1.1.8 Model 13

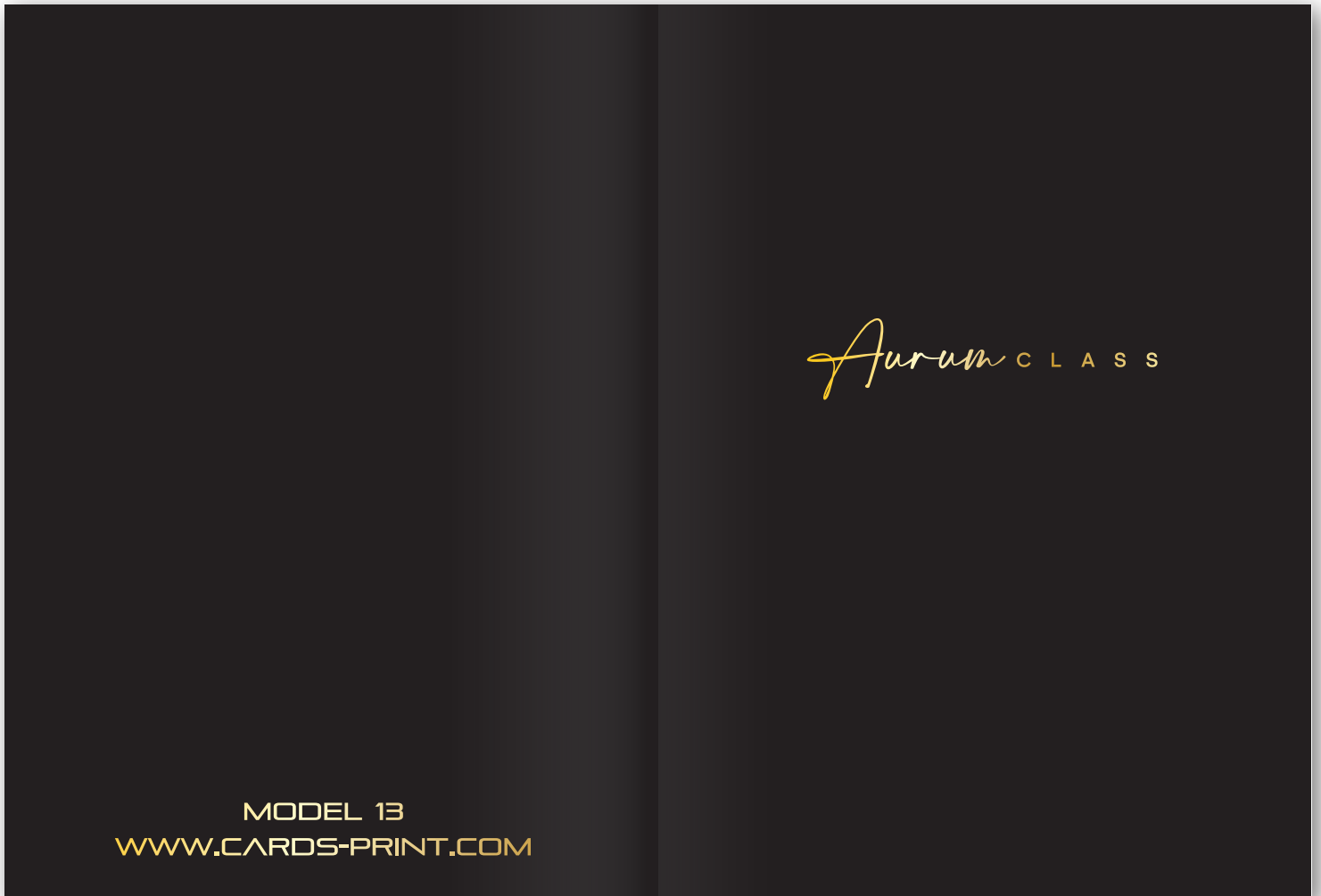

DIMENSION OF ASSEMBLED HOLDER		DIMENSION OF PREPARATION WITHOUT BLEED		Bleed
width	height	width	height	
73 mm	100 mm	188 mm	147 mm	It is necessary to leave 3 mm ON ALL SIDES

1.1 HOLDERS

1.1.9 Model 14

LEGEND

- Cutting
- Creasing
- Perforation

Outside tool

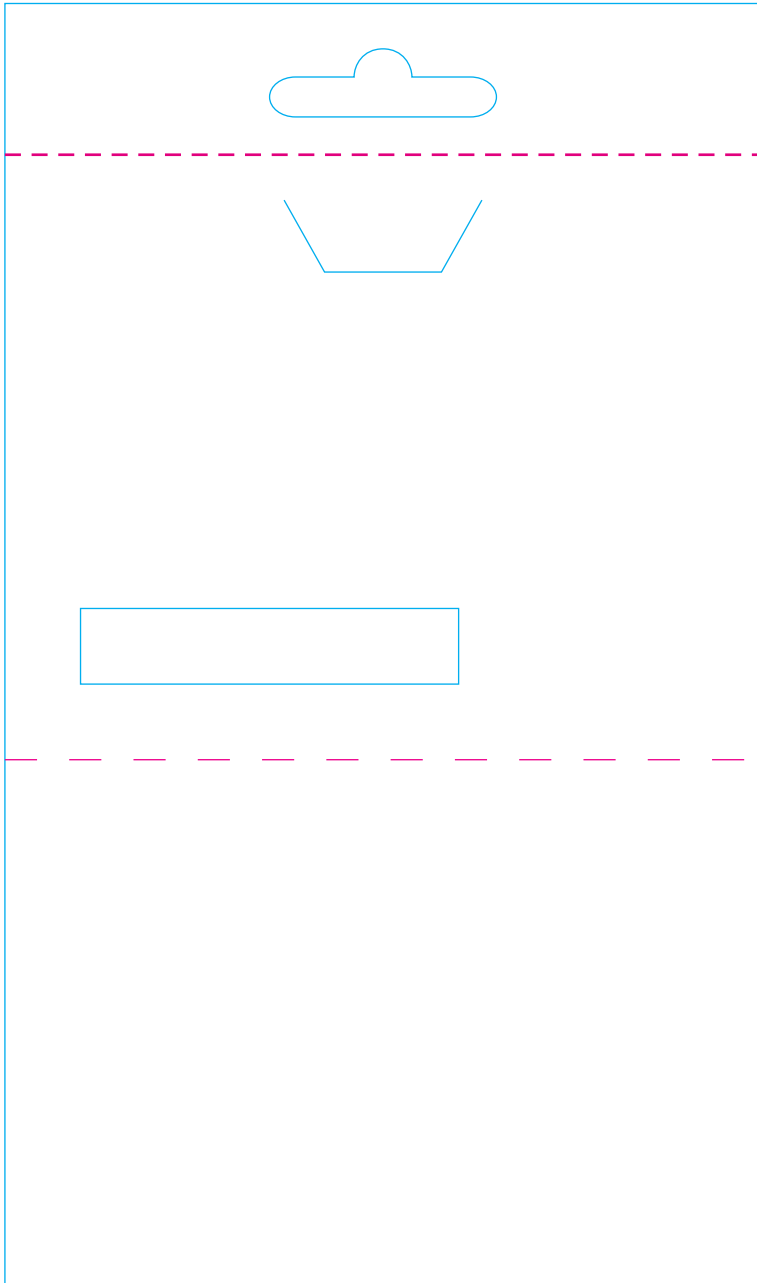

Inside tool

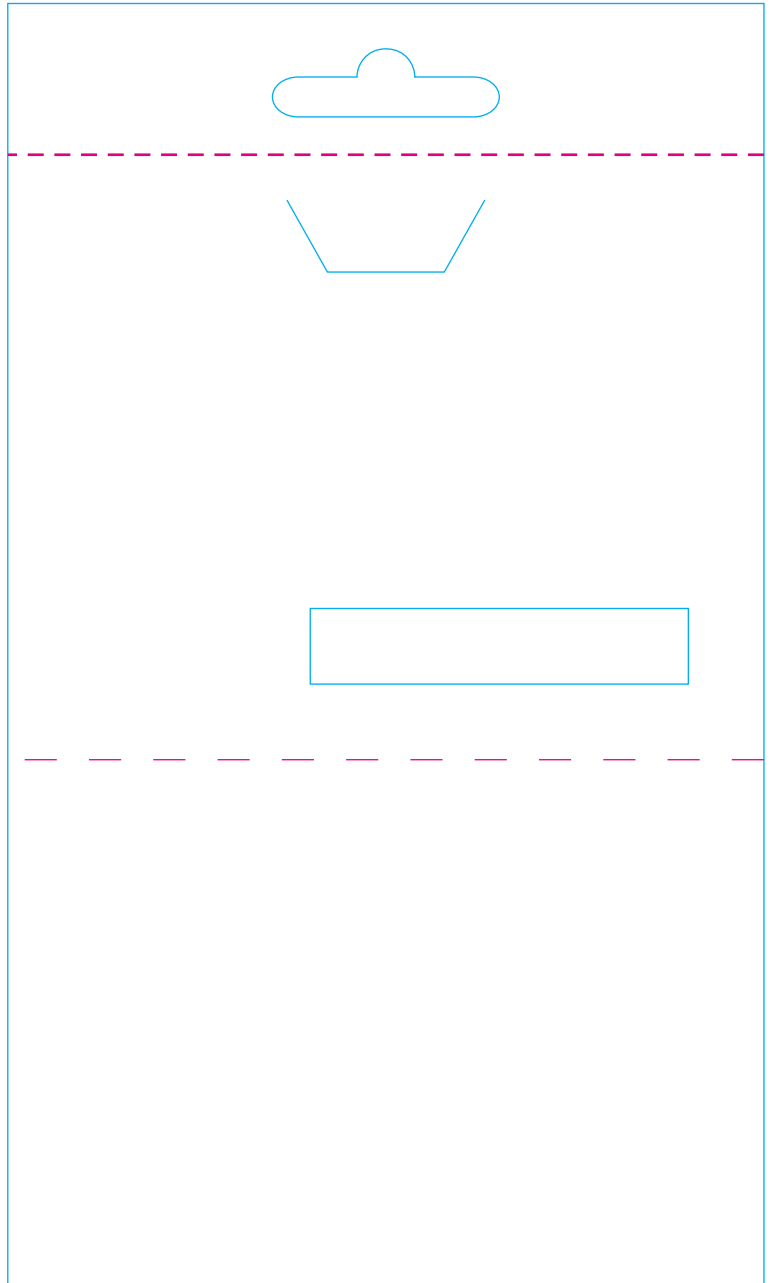

1.1 HOLDERS

1.1.9 Model 14



DIMENSION OF ASSEMBLED HOLDER		DIMENSION OF PREPARATION WITHOUT BLEED		Bleed
width	height	width	height	
100 mm	100 mm	100 mm	170 mm	It is necessary to leave 3 mm ON ALL SIDES

1.1 HOLDERS

1.1.10 Model 15

LEGEND

- Cutting 
- Creasing 
- Perforation 

Outside and inside tools

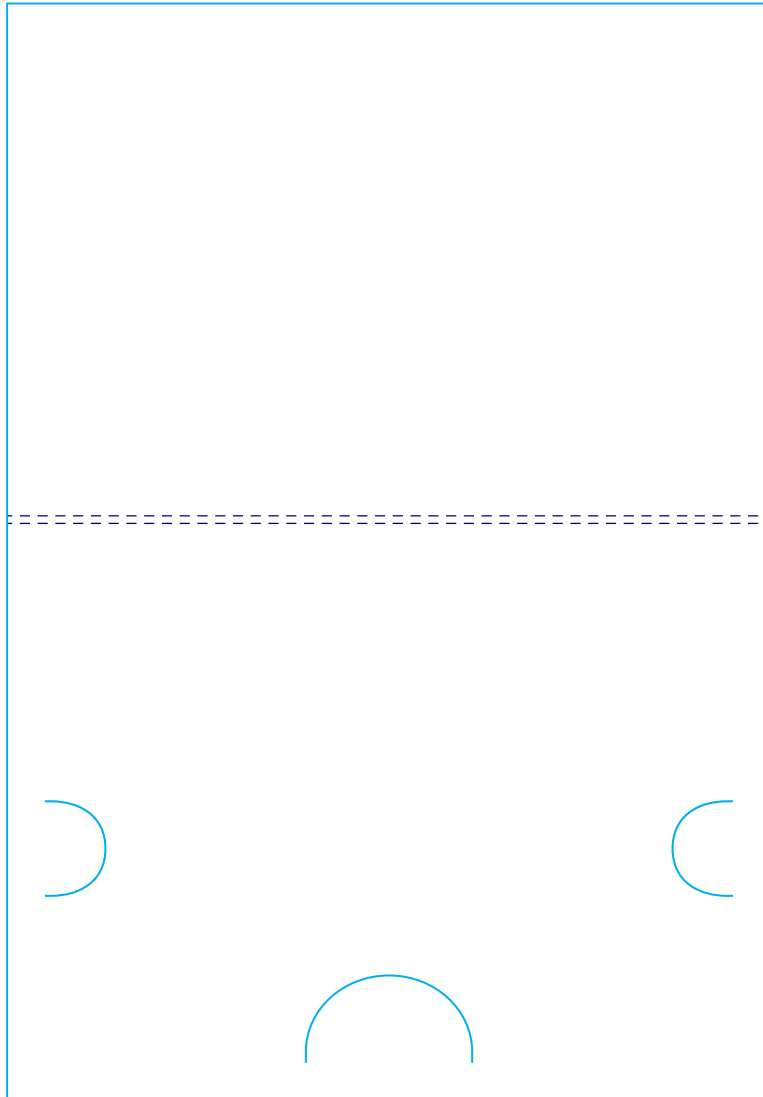

1.1 HOLDERS

1.1.10 Model 15



DIMENSION OF ASSEMBLED HOLDER		DIMENSION OF PREPARATION WITHOUT BLEED		Bleed
width	height	width	height	
101 mm	77 mm	101 mm	145 mm	It is necessary to leave 3 mm ON ALL SIDES

1.1 HOLDERS

1.1.11 Model 16

Outside tool

LEGEND

Cutting ———
Creasing - - - - -
Perforation ·····

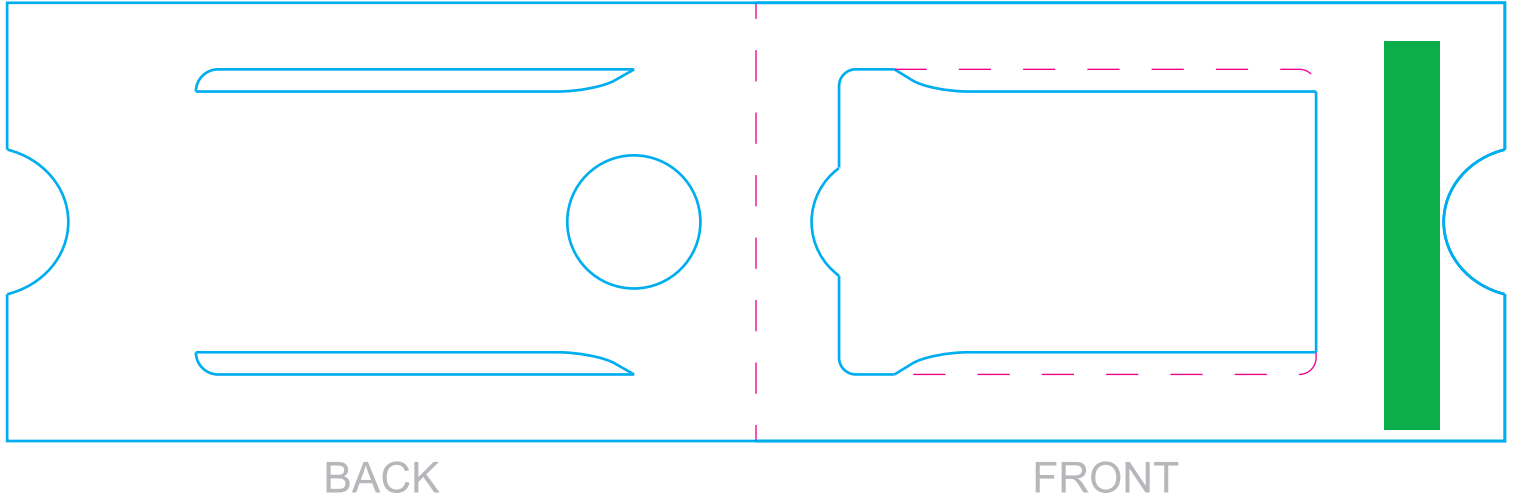

Inside tool

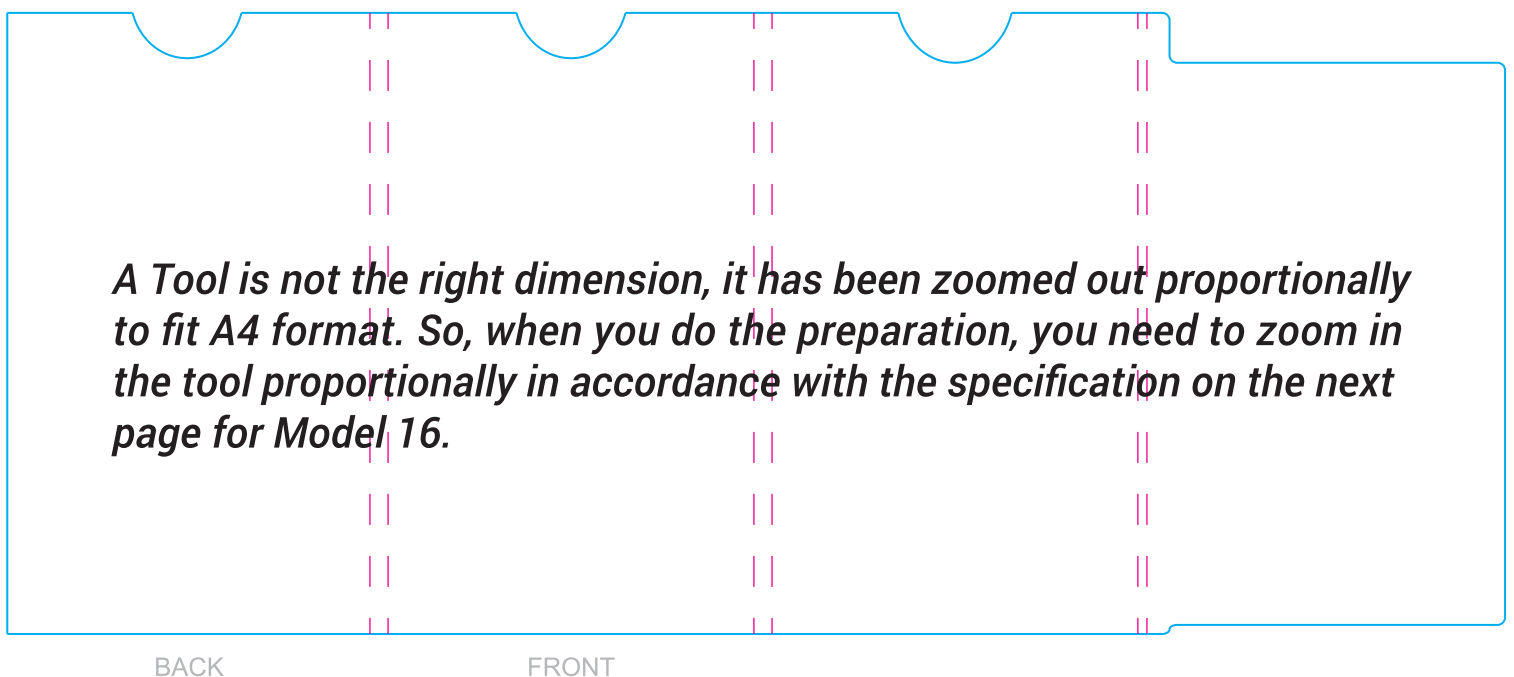
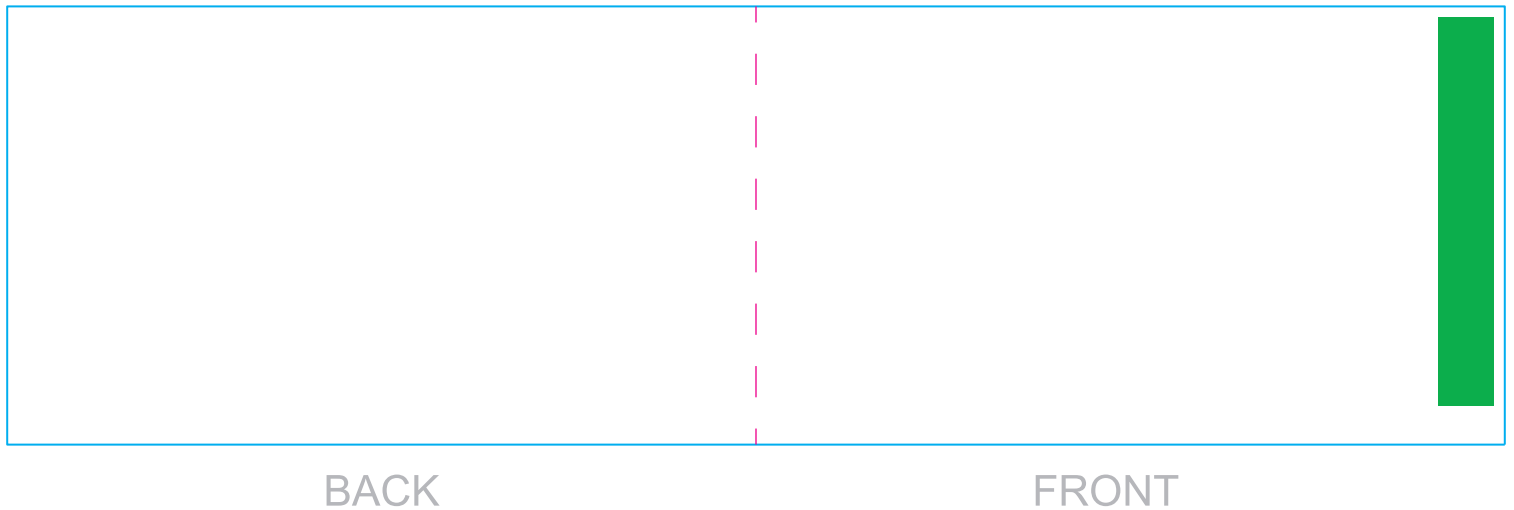

A Tool is not the right dimension, it has been zoomed out proportionally to fit A4 format. So, when you do the preparation, you need to zoom in the tool proportionally in accordance with the specification on the next page for Model 16.

1.1 HOLDERS

1.1.11 Model 16



DIMENSION OF ASSEMBLED HOLDER		DIMENSION OF PREPARATION OF THE CENTRAL PART WITHOUT BLEED		Bleed
width	height	width	height	
135 mm	79 mm	270 mm	79 mm	It is necessary to leave 3 mm ON ALL SIDES
		DIMENSION OF PREPARATION OF THE WORK TO BE DRAWN WITHOUT BLEED		
		330 mm	137 mm	

1.2 APPLICATION FORMS

1.2.1 Model 01

LEGEND

Cutting	
Creasing	
Perforation	

Outside tool



Inside tool

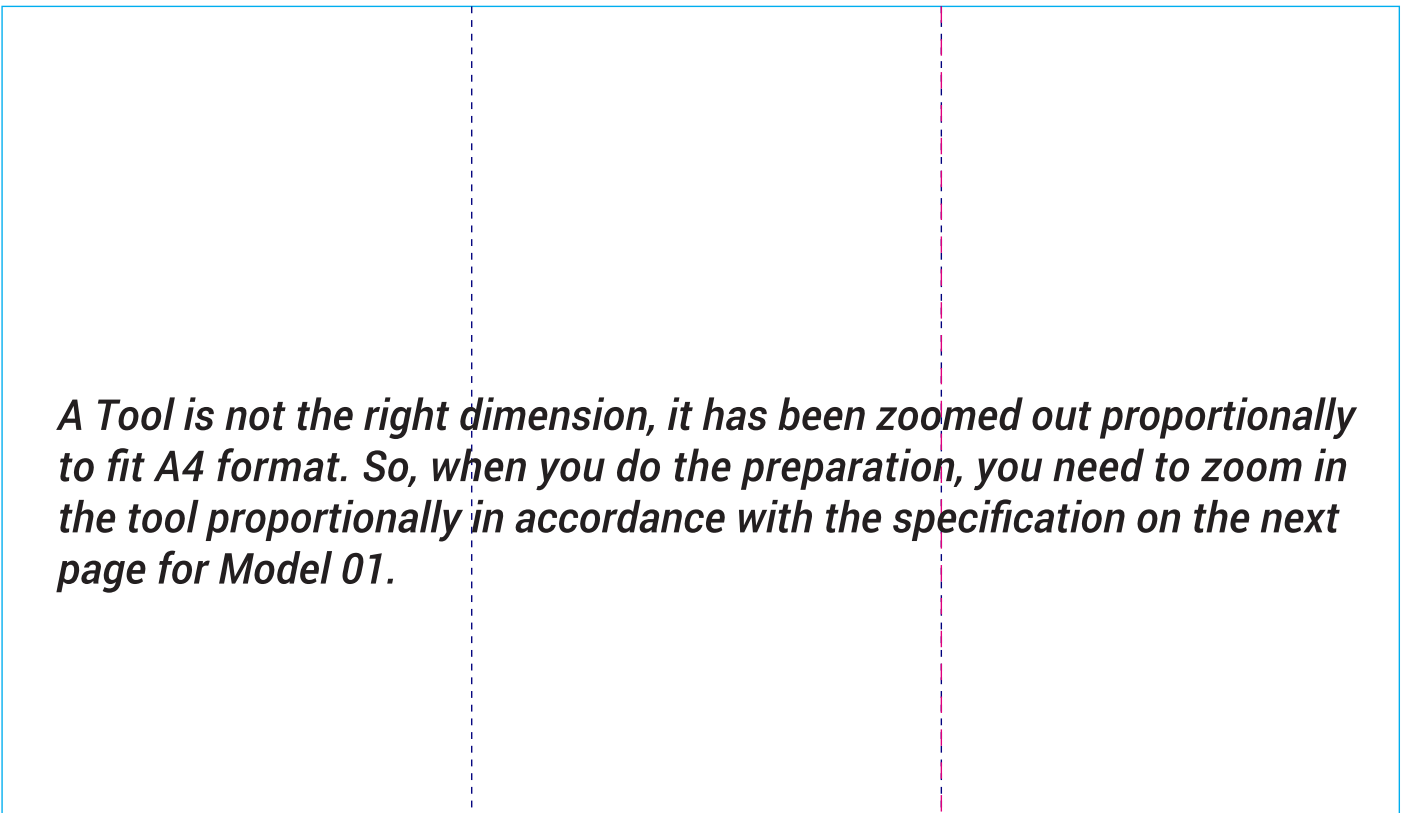

1.2 APPLICATION FORMS

1.2.1 Model 01



DIMENSION OF ASSEMBLED APPLICATION FORM		DIMENSION OF PREPARATION WITHOUT BLEED		Bleed
width	height	width	height	
118 mm	210 mm	360 mm	210 mm	It is necessary to leave 3 mm ON ALL SIDES

1.2 APPLICATION FORMS

1.2.2 Model 02

LEGEND

Cutting ———
 Creasing - - - - -
 Perforation ·····

Outside tool

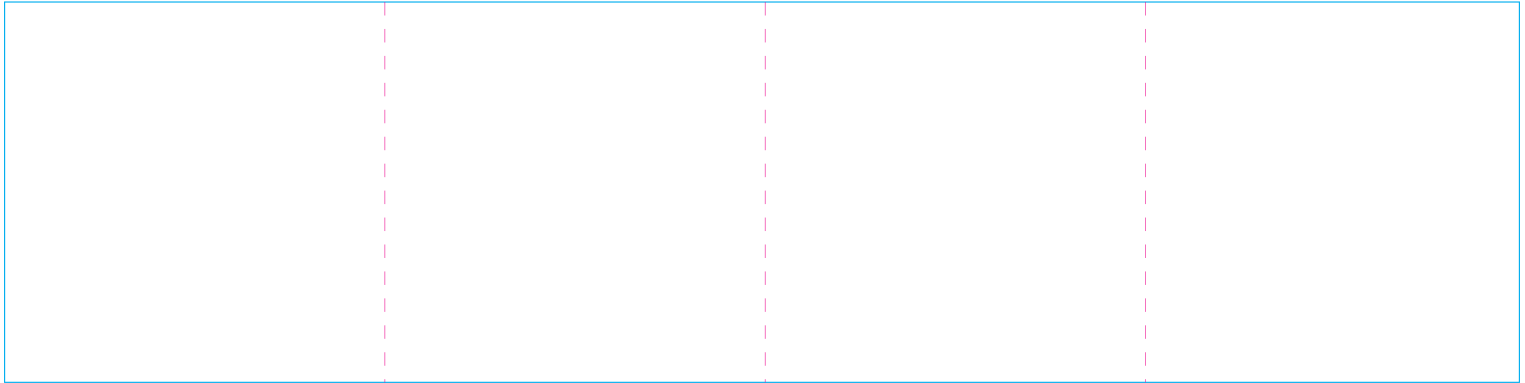

Inside tool

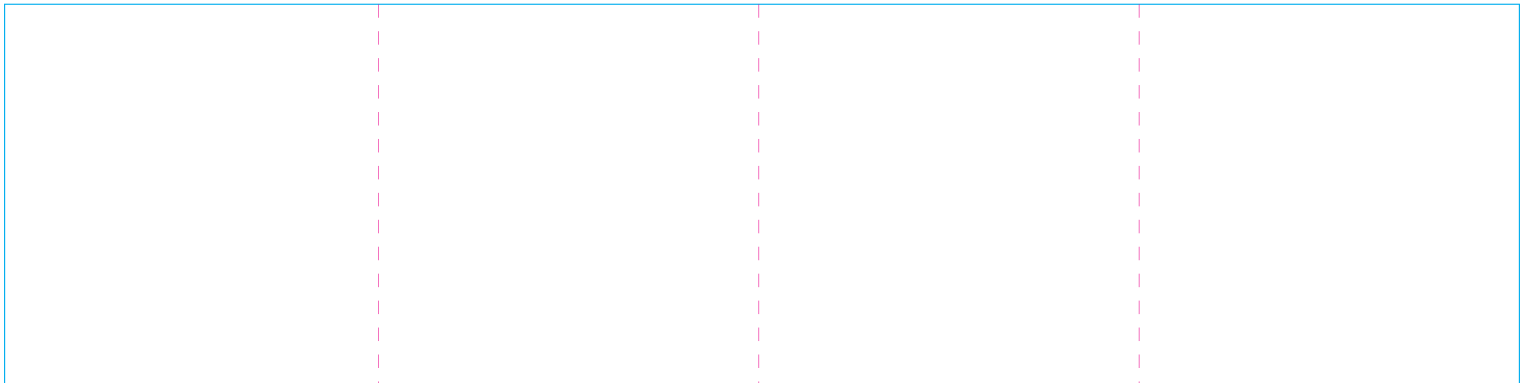

A Tool is not the right dimension, it has been zoomed out proportionally to fit A4 format. So, when you do the preparation, you need to zoom in the tool proportionally in accordance with the specification on the next page for Model 02.

1.2 APPLICATION FORMS

1.2.2 Model 02



DIMENSION OF ASSEMBLED APPLICATION FORM		DIMENSION OF PREPARATION WITHOUT BLEED		Bleed
width	height	width	height	
118 mm	120 mm	478 mm	120 mm	It is necessary to leave 3 mm ON ALL SIDES

1.2 APPLICATION FORMS

1.2.3 Model 03

LEGEND

Cutting	
Creasing	
Perforation	

Outside and inside tools

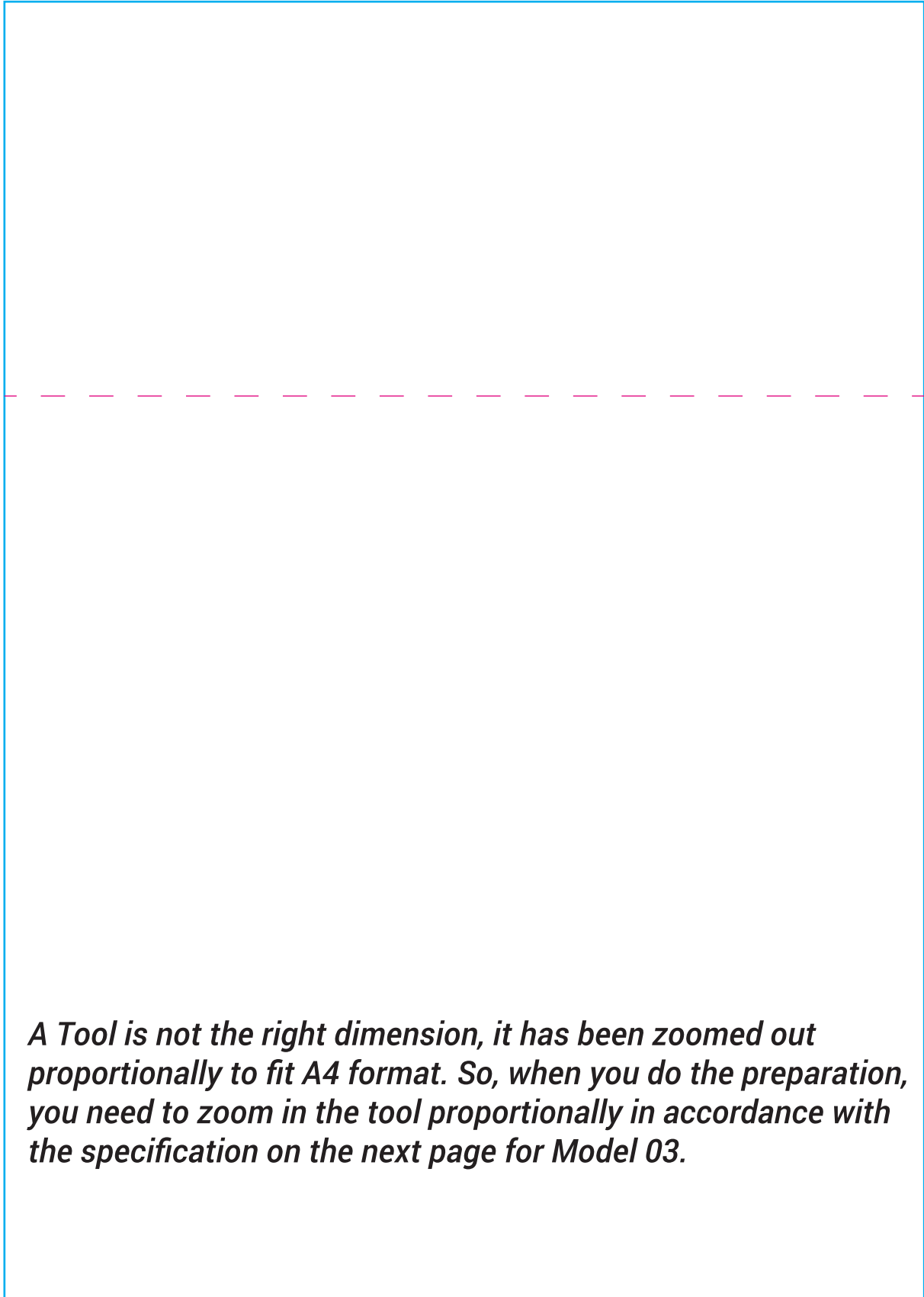

A Tool is not the right dimension, it has been zoomed out proportionally to fit A4 format. So, when you do the preparation, you need to zoom in the tool proportionally in accordance with the specification on the next page for Model 03.

1.2 APPLICATION FORMS

1.2.3 Model 03

PREDNJA STRANA

ZADNJA STRANA



MODEL NO 03

PRISTUPNICA



THE PLASTIC CARD SPECIALISTS

OBRAZAC PRIJAVE ZA KARTICU LOJALNOSTI

MOLIMO POPUNITE TRAŽENE PODATKE VELIKIM SLOVIMA.

Ime*: _____

Prezime*: _____

Pol*: M Ž

Ulica i broj: _____

Poštanski broj*: _____

Grad*: _____

Država / Pokrajina: _____

Zemlja*: _____

Broj mobilnog telefona*: _____

E-mail*: _____

Datum rođenja* (d/m/gg): _____

Želim da se registrujem za kupovinu putem Interneta na adresi www.cardsprint.rs i da mi se akreditiraju korisnika šaljku na moju ulicu ili adresu e-pošte:

DA NE

IZJAVA

Ja, niže potpisano Lice izjavljujem da mi je unučena kartica lojalnosti kao i da sam pročitao i razumeo Obaveštenje sa ove pristupnice, te ovim putem izjavljujem sledeće:

- da sam saglasan da moje lične podatke koje dostavljam Rukovodcu u skladu sa Obaveštenjem, Rukovodac obrađuje i koristi u skladu s odredbama iz Obaveštenja i odredbama važećeg Zakona o zaštiti podataka o ličnosti;
- da svoje podatke o ličnosti dajem dobrovoljno;
- da Rukovodac podataka koje navedene podatke može da prikuplja i skladišti posredstvom softverskog sistema i da ih koristi u svrhu realizacije Programa Lojalnosti, kao i u svrhu navedene u Obaveštenju, uključujući direktni marketing, profilisanje, statističku obradu i komunikaciju sa mnom;
- da ću za ostvarenje svojih prava koje mi pripadaju (uključujući i pravo na opoziv pristanka) prevashodno kontaktirati Rukovodca putem nekog od kontakata navedenog u Obaveštenju;

U _____ Dana _____ Ime i prezime davoca izjave _____ Svojeručni potpis davoca izjave _____



BARKOD NALEPNICA



T. +381 11 41 41 540
info@cardsprint.rs
Novosajanski put 38a,
26000 Pan evo, Srbija
www.cardsprint.rs

PRAVILA PROGRAMA LOJALNOSTI

1. Kartica lojalnosti izdaje Cards Print d.o.o. Novosajanski put 38a, 26000 Pan evo. Kartica lojalnosti je vlasništvo izdavaoca kartice.
2. Članstvo u programu lojalnosti je besplatno.
3. Sveka punoletna osoba sa prebivalištem u Republici Srbiji koja je prethodno popunila obrazac za članstvo može postati punopravno upisani član programa lojalnosti i vlasnik kartice.
4. Popunjeni obrazac za prijavu podnosi se na navedenom mestu u Cards Print. Nakon podnošenja prijave, zaposlenik kompanije Cards Print predaje karticu lojalnosti novom članu.
5. Kartica lojalnosti nije sredstvo plaćanja.
6. Kartica lojalnosti je prenosiva, tako da je mogu koristiti i članovi porodice.
7. Kartica lojalnosti važi od datuma izdavanja.
8. Predstav kartica lojalnosti za kupca je popust u iznosu prikupljenih bodova. Bodovi se oseseju kupovinom na Cards Print.
9. Prikupiti bodovima u gotovini, debitnim ili kreditnim karticama (American Express, Visa, Eurocard / Mastercard) za sveukupno 1 000 potrošenih dinara, član ima pravo na 1 poen.
10. Jedan bod vredi 100 dinara.
11. Za prikupljanje bodova nakon registracije potreban je minimalni iznos kupovine od 1 000 dinara po računu.
12. Prikupljeni bodovi se ne mogu zamisliti za gotovinu.
13. Dostimo stimulisano članove koji obavljaju pojedinačne kupovine veće vrednosti - za kupovinu u vrednosti od najmanje 10 000 dinara, za sveukupno 1 000 potrošenih dinara po članu računa pripada 2 boda.
14. Član je dužan da karticu lojalnosti predloži pre početka plaćanja na prodajnom mestu tako bi u nju zabeležio nove bodove (Bodovi 9, 10, 11, 12 i 13), odnosno radi ostvarenja prava na popust na kupovinu u iznosu prikupljenih bodova.
15. Da biste ostvarili pravo na popust na kupovinu u iznosu prikupljenih bodova, potrebno je prikupiti najmanje 50 bodova.

OBAVEŠTENJE I IZJAVA O SAGLASNOSTI ZA PRIKUPLJANJE, OBRADU I KORIŠĆENJE PODATAKA O LIČNOSTI

OBAVEŠTENJE

U skladu sa Zakonom o zaštiti podataka o ličnosti, oim Obaveštenjem (u daljem tekstu: Obaveštenje) izdatim licima pružamo informacije u vezi sa obradom podataka o ličnosti (u daljem tekstu: Lice), te Lice potpisivanjem izjave na osnovu ovog Obaveštenja, dala saglasnost da V OVO mesto, odnosno: Republika Srbija, M.P. PIB: ... u saglasnost sa obradom podataka (u daljem tekstu: Rukovodac) svih podataka o ličnosti u cilju realizacije programa lojalnosti „My SportLife“ - putem marketinških aktivnosti, uključujući i direktni marketing, profilisanje (u daljem tekstu: Program Lojalnosti).

1. Rukovodac podataka
Rukovodac podataka je ...
Podatke koji se prikupljaju od Vas koristimo isključivo Rukovodac podataka i Lice sa kojima Rukovodac podataka ima ugovor o obradi podataka, uključivo u svrhu navedenu u ovom Obaveštenju.

2. Kontakt
U vezi sa svim zahtevima koje se odnose na podatke o ličnosti, Lice sa nama obratiti Rukovodcu na neke od sledećih načina: Email: _____; Posetska adresa: _____; Telefon: +381 _____.

3. Kategorije podataka o ličnosti koji se obrađuju su sledeće:
Rukovodac podataka, na osnovu izjave prikuplja, obrađuje i koristi sledeće kategorije ličnih podataka o ličnosti:
1. imi i prezima
2. broj mobilnog telefona
3. adresa elektronske pošte (e-mail adresa) ...
Upisivanjem podataka na obrazac, Lice daje saglasnost Rukovodcu da upisane podatke prikuplja, obrađuje i koristi za svrhu navedenu u Obaveštenju i Izjavi, a u skladu sa Zakonom o zaštiti podataka o ličnosti.

4. Svrha obrade i pravni osnov obrade
Podaci o ličnosti se obrađuju na osnovu Zakona o zaštiti podataka o ličnosti i na osnovu saglasnosti Lica (Član 12. stav 1. tačka 1) koji Lice dala Rukovodcu potpisom na Izjavi. Podaci o ličnosti prikupljaju, obrađuju i koriste se u cilju:
- ostvarenja Programa Lojalnosti putem marketinških aktivnosti, uključujući direktni marketing i profilisanje;
- pružanja i prilagođavanja usluga koje odgovaraju konkretnim potrebama Lica na koje se podaci odnose, kao i u cilju unapređenja odnosa između Lica i Rukovodca podataka.

Obrada i obrada podataka o ličnosti je neophodan uslov za realizaciju Programa Lojalnosti, te je Lice niče da pruži podatke o svojoj ličnosti samo ukoliko želi da bude uključeno u Program Lojalnosti.

Program Lojalnosti nije moguće realizovati u slučaju neprijava Obaveštenjem (u daljem tekstu: Obaveštenje) izdatim licima, kao i bilo kojim drugim razlogom prestanka obrade i korišćenja ovih podataka. Rukovodac podataka neće biti podvrgnut o ličnosti davanima korisnika bez njihove izjave. Izjava koja je na licu mesta obavezan zakonom i odlukom nadležnog državnog organa. Podaci o ličnosti se koriste na sve zakonite propisane načine, što obuhvata ali se ne ograničava na prikupljanje, beleženje, unapređivanje, pretraživanje, razvrstavanje, pohranjivanje, razvijanje, usvajanje, automatski, poluautomatski ili na drugi način.

5. Rok čuvanja podataka o ličnosti
Rukovodac podataka će podatke o ličnosti koji su prikupljeni u cilju realizacije Programa Lojalnosti, odnosno sve dok traje realizacija Programa Lojalnosti, odnosno sve dok je Lice na koje se podaci odnose uključeno u realizaciju Programa Lojalnosti, oim u slučajevima kada je Rukovodac podataka u obavezi da podatke čuva i nakon okončanja Programa Lojalnosti u skladu sa zakonom kojim se uređuje neobnovljive.

Podaci o ličnosti koji se obrađuju uključuju por osnovu pristanka Lica na koje se podaci odnose se obrađuju i u skladu sa svrhom zbog koje su prikupljeni, odnosno do opozita pristanka odnosno ponovljenog saglasnosti od strane Lica na koje se podaci odnose ili drugih slučajeva prestanka pravne osnov za obradu podataka o ličnosti u skladu sa Zakonom.

6. Izmeštanje podataka u drugu državu
Rukovodac podataka o ličnosti neće prenositi u drugu državu koja je članica Konvencije Saveta Evrope o zaštiti lica u odnosu na automatsku obradu ličnih podataka, odnosno u državu za koju od strane Evropske unije utvrđeno da obezbeđuje pravnenu i učnu zaštitu u skladu sa Članom 64. Zakona o zaštiti podataka o ličnosti.

7. Prava Lica na koje se podaci odnose u vezi sa obradom podataka o ličnosti
Lice na koje se podaci odnose ima pravo na pristup podacima o ličnosti koji su obrađuju od strane Rukovodca podataka. Lice na koje se podaci odnose ima pravo da zahteva ispravu, ažuriranje, brisanje podataka, kao i predvi i privremeno obustavu obrade na način propisan zakonom.

Lice na koje se podaci odnose ima pravo da u svakom trenutku podnese prigovor na obradu podataka o ličnosti koji se na istoj odnosi.

Lice na koje se podaci odnose ima pravo da prenevanje podataka o ličnosti, odnosno pravo da podatke koji je prethodno dostavilo Rukovodcu podataka vrati u vidu, u nudi prenosu drugim rukovodacima podataka, kao i pravo da podaci o ličnosti budu neposredno preneseni drugim rukovodacima od strane Rukovodca podataka, ukoliko je u tome izjavilo i ukoliko je u skladu sa pravom Rukovodca podataka, obezbeđen potreban standard bezbednosti prenosa podataka o ličnosti.

Lice na koje se podaci odnose ima pravo da se vrati podaci o ličnosti bez obziranja ispravu, kao i da se nepotpuni podaci o ličnosti dopune, uključujući ispravu dodatne izjave, ukoliko je to potrebno slobodno vrati.

Lice na koje se podaci odnose ima pravo da od Rukovodca podataka zahteva informaciju da li je njegov podaci obraduju, pristup informacijama, kao i istovajanje kopije podataka koji se obrađuju. Kopije se izdaju uz naknadu opravanih troškova za izradu dodatnih kopija.

Lice na koje se podaci odnose može u svakom trenutku da opozove pristanku, odnosno povuče svoju saglasnost za obradu podataka i zahtevati brisanje svojih podataka, potom ispisane izjave postaje Rukovodcu podataka (kako je gore navedeno), u kom slučaju će Rukovodac podataka prekinuti svaku dalju obradu Podataka o ličnosti i iste obraditi u sagovetnih baza podataka, s tim da valid navedenog Lica na koje se podaci odnose biva uključeno u Program Lojalnosti i nastavlja raditi neke mest prava i mogućnosti koje se istim pružaju.

U slučaju neostvarenja obrade, Lice na koje se podaci odnose ima pravo na brisanje podataka. **8. Prava na prigovor**
Lice na koje se podaci odnose ima pravo da u svakom trenutku podnese prigovor na obradu podataka o ličnosti koji se obrađuju u cilju direktnog marketinga, uključujući i profilisanje, u mestu u kojoj je bilo pristanka sa direktnim marketingom, u kom slučaju se podaci Lica na koje se podaci odnose ne smaju dalje obrađivati u cilju direktnog marketinga.

9. Prava na približavanje
Lice na koje se podaci odnose ima pravo da učini približbu nadležnom organu (Povernika za informaciju od javnog značaja i zaštiti podataka o ličnosti, www.povernik.rs) na obradu svojih podataka o ličnosti od strane Rukovodca podataka, ako smatra da je obrada podataka o ličnosti u skladu sa zakonom i postupkom odobrenja Zakona o zaštiti podataka o ličnosti, u skladu sa Članom 62. tog Zakona. Pritužbene priče Poverniku su otvore na pravo zbog lica da potvrdi druge podatke upravne ili sudne zaštite.

10. Slabaša davanja saglasnosti i moguće posledice nedavanja saglasnosti za obradu podataka o ličnosti
Davanje saglasnosti za obradu podataka o ličnosti je dobrovoljno i zasnovano na slobodnoj i bez pritiska izjavi Lica na koje se podaci odnose, i to putem samovoljnog potpisivanja izjave.

11. Postupanje automatizovanog donošenja odluka, uključujući profilisanje
U okviru realizacije Programa Lojalnosti Rukovodac podataka primenjuje tehnike računanja, polu automatizovanog i automatizovanog donošenja odluka, uključujući i profilisanje, u cilju pružanja i prilagođavanja usluga koje odgovaraju konkretnim potrebama Lica na koje se podaci odnose, kao i u cilju ostvarenja svih većih pogodnosti (benefita) Lica na koje se podaci odnose u skladu s Programu Lojalnosti, koji imaju licu moguć dostup, posebne pogodnosti (benefita), uključujući i finansiranje (popusti, bonusi, paketi i sl) koji su Lice na koje se podaci odnose odnosa u konkretnoj usluzi, odnosno kupovni robu iz asortimana Rukovodca.

Rukovodac preduzima odgovarajuće organizacione, tehničke i kadrovske mere kako bi zaštitio lične podatke o ličnosti Lica na koje se podaci o ličnosti odnose, uz primenu standarda na polju obezbeđenja ličnosti i elektronskih signatur podataka. Podatke o ličnosti Rukovodac čuva kao poverljive informacije.

DIMENSION OF ASSEMBLED APPLICATION FORM		DIMENSION OF PREPARATION WITHOUT BLEED		Bleed
width	height	width	height	
210 mm	297 mm	210 mm	297 mm	It is necessary to leave 3 mm ON ALL SIDES

CHAPTER 2

INSTRUCTIONS FOR PRODUCING FILES



2.1 BASIC REQUIREMENT

2.1.1 General

Preparation needs to be in CMYK colour mode so that the printing file can be used.

File must be prepared following the dimensions set.

All linked images within the working file must be **EMBEDDED**.

2.1.2 Colors and objects

Colour values and vector objects must be prepared in CMYK colour palette.

Black needs to be from carbon only (C:0% M:0% Y:0% **K:100%**).

Grey should also be from pure carbon in order to get pure grey.

Bitmap objects should be prepared at 300dpi in .JPG format.

2.1.3 Personalisation

Personalisation elements, including bar codes, signature strip and other, should be prepared in the form of vector object.

Text personalisation

We need to convert the whole text that does not need to be personalised into curves (make it unchangeable and uneditable and then when opened on some other computer, it will not require fonts).

Sending the font is obligatory for the text that is personalised.

We convert fonts into curves by clicking on the text (select/object/all text objects if we want to mark the whole text), then type/create outlines(ctrl+shift+O).

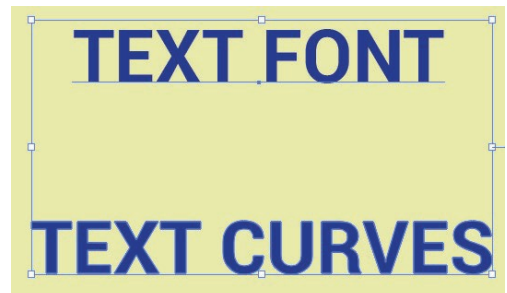

The example of the text preview in fonts and curves.

2.2 SETTING-UP THE CONTENT

2.2.1 Bleed

Graphic elements must be positioned up to the overhang line.

 WRONG

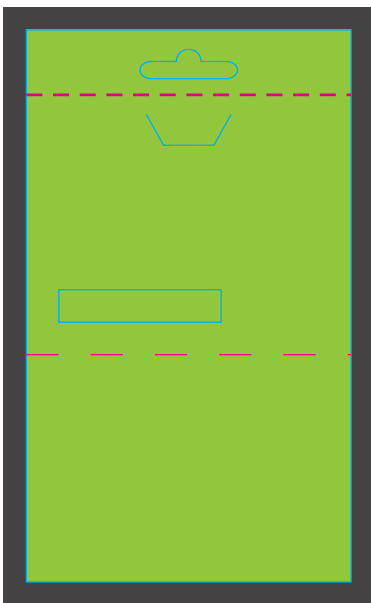

 CORRECT

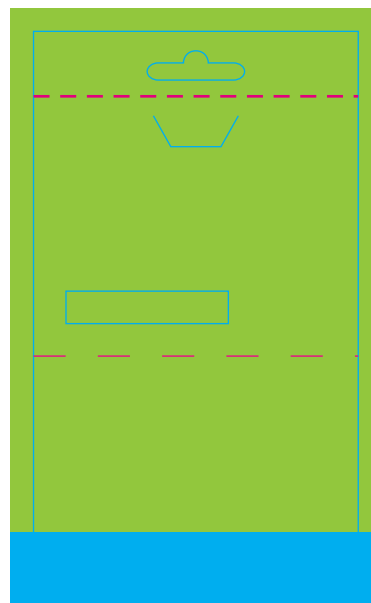
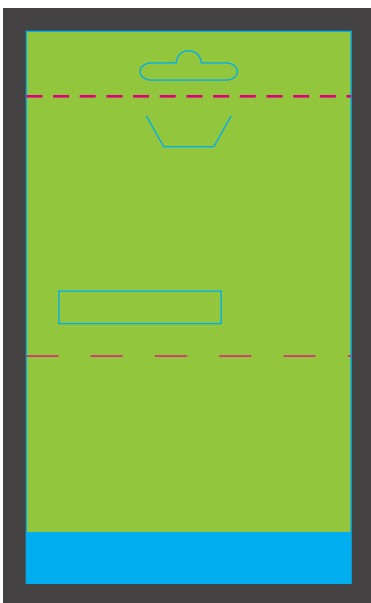
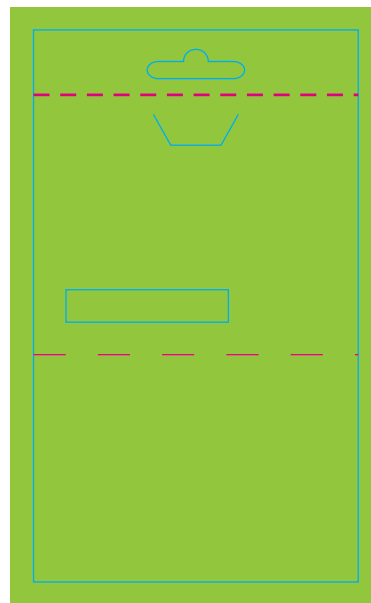

2.2 SETTING-UP THE CONTENT

2.2.2 Safe zone

To prevent graphic elements from getting to the cutting line, it is very important to position them within **safe zone**. Safe zone is 1.5mm from the cutting line.

Images need to be embedded when implementing them within your design. You can do it in Adobe *illustrator* by clicking the **'Embed'** button in the upper left corner of the *illustrator* window..

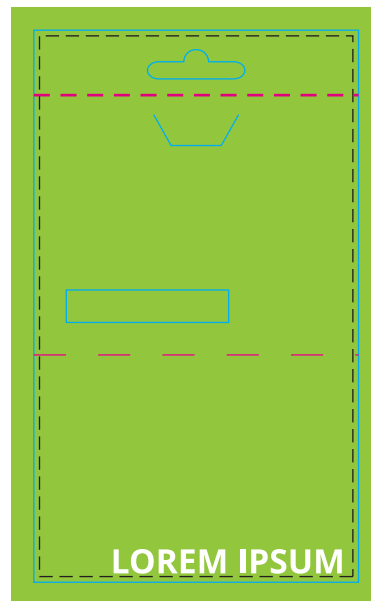
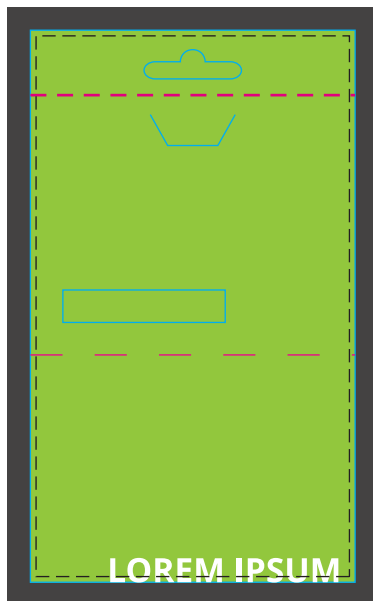

2.2 SETTING-UP THE CONTENT

2.2.3 Preparation of background for perforation

Colours or elements in the background should not have sharp gradation with perforation or creasing but we recommend a single transition in gradient way, one-colour background or graphics/image whose elements do not necessarily reach perforation or creasing line.

 NOT RECOMMENDED

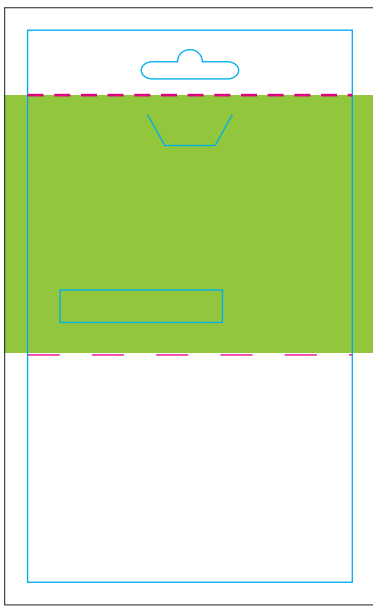

 RECOMMENDED

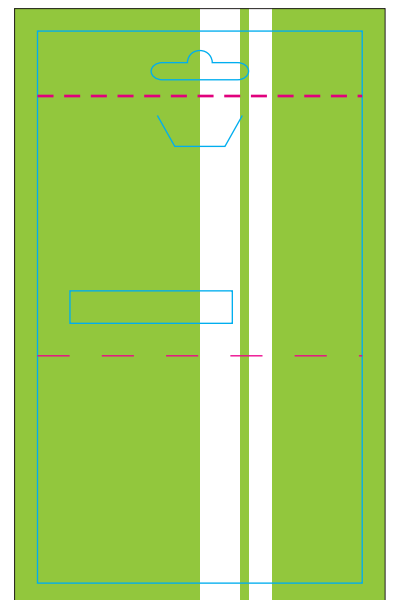
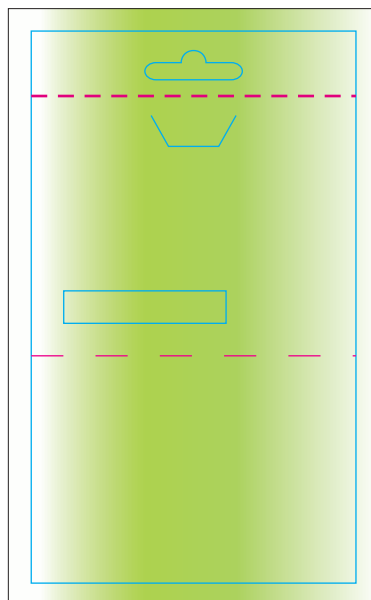
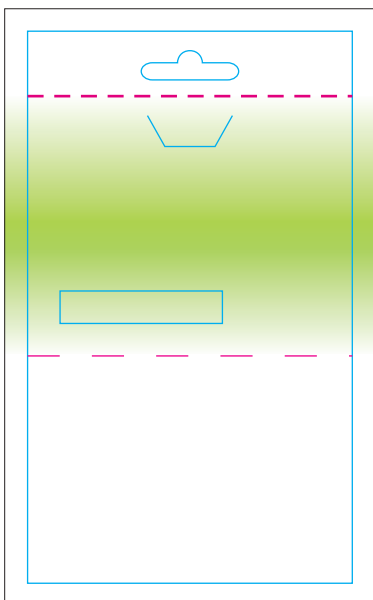

CHAPTER 3

RECOMMENDATIONS



3.1 SOFTWARE

3.1.1 Software selection

We recommend using softwares by the company **Adobe Systems Incorporated** to achieve the easiset compatibility with computing standards.

Each software has its own specific role and does not necessarily give the best solution for printing which also includes the software by the company **Adobe**.

For instance, it is usually mistakenly believed that one of **Adobe Photoshop** functions is saving in PDF format keeping vector layers. What is actually extracted is not a vector object with typical characteristics for this class but raster layers of bitmaps which makes a different type of object.

That's why efficient use of this object is not possible, so the printing quality could be lower than expected.

This is exactly the reason why our choice is Adobe Illustrator which contains original vector objects and exports it in PDF in accordance with the standards.

3.1.2 Effects and filters

Tools such as filters, shades, gradients etc. may vary through different versions of the software used. That is the reason why we strongly recommend a detailed checking of the preview we send you for confirmation as well as the sample if we deliver it to you.

3.2 COLORS

3.2.1 Overprint

Overprint option includes values of the covering colours. Covering colour means rewriting or reprinting over other colours.

A common mistake in preparation for printing is when black is not set to overprint but it covers them.

The most common problem in that case is black letters which are then very difficult to fit into printing. The most common lapse happening is photoshop files because it is not set to overprint black.

OVERPRINT option is not recommended for the type of printing we do.

3.3 TYPES OF FILES

Files we recommend:

- Ai
- PDF
- CDR
- EPS
- SVG

Files we do not recommend:

Partial or complete inability to correct or adapt to the type of printing.

- PSD
- JPG

CHAPTER 4

ADDITIONAL INFORMATION



4.1 SCOPE OF RESPONSIBILITY

Bear in mind that the company **Cards Print** is solely responsible for technical part of printing and shall not bear liability for the file client sends, the way it was created and the extent the abovementioned files match our specification.

Not following requests and recommendations listed in this specification can make the file unusable or cause poorer quality than expected. In case a client wants to change the file, our design team estimates the file and informs the client of the corrections requested that can be made.

4.2 CHECKLIST

- Correct file (Vector format)
- Vector elements within the file
- Following safe zone
- Leaving bleed
- Dimensions in accordance with specification
- Colours is CMYK
- Text in curves
- Fonts for personalisation
- Images Embedded within the file (JPG, 300dpi)
- Effects, fliters and overprint
- Background with perforation