

TECHNICAL SPECIFICATION

FOR PREPARATION OF HOLDERS AND APPLICATION FORMS PRINTING



CARDS PRINT

Novoseljanski put 38d, 26000 Pancevo, Serbia

+381 11 41 41 540

info@cards-print.com | www.cardsprint.com



THE PLASTIC CARD SPECIALISTS



www.cardsprint.com

Content

1. MODELS & DIMENSIONS

1.1 HOLDERS

- 1.1.1 Model 01
- 1.1.2 Model 02
- 1.1.3 Model 03
- 1.1.4 Model 06
- 1.1.5 Model 10
- 1.1.6 Model 13
- 1.1.7 Model 15
- 1.1.8 Model 16
- 1.1.9 Model MK 01
- 1.1.10 Model MK 02
- 1.1.11 Model MK 03
- 1.1.12 Model MK 05

1.2 APPLICATION FORMS

- 1.2.1 Model 01
- 1.2.2 Model 02
- 1.2.3 Model 03

2. INSTRUCTIONS FOR PRODUCING FILES

2.1 BASIC REQUIREMENTS

- 2.1.1 GENERAL
- 2.1.2 COLORS AND OBJECTS
- 2.1.3 PERSONALISATION

2.2 SETTING-UP THE CONTENT

- 2.2.1 BLEED
- 2.2.2 SAFE ZONE
- 2.2.3 PREPARATION OF BACKGROUND FOR PERFORATION

3. RECOMMENDATIONS

3.1 SOFTWARE

- 3.1.1 SOFTWARE SELECTION
- 3.1.2 EFFECTS AND FILTERS

3.2 COLORS

- 3.2.1 OVERPRINT

3.3 TYPES OF FILES

4. ADDITIONAL INFORMATION

4.1 SCOPE OF RESPONSIBILITY

4.2 CHECKLIST

CHAPTER 1

MODELS & DIMENSIONS

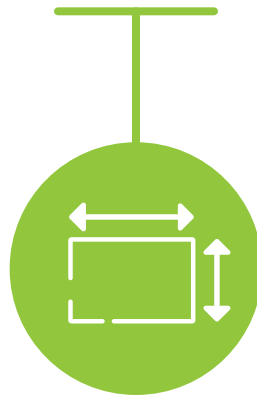

1.1 HOLDERS

1.1.1 Model 01

Outside and inside tools

LEGEND

Cutting ———
Creasing - - - - -
Perforation ·····

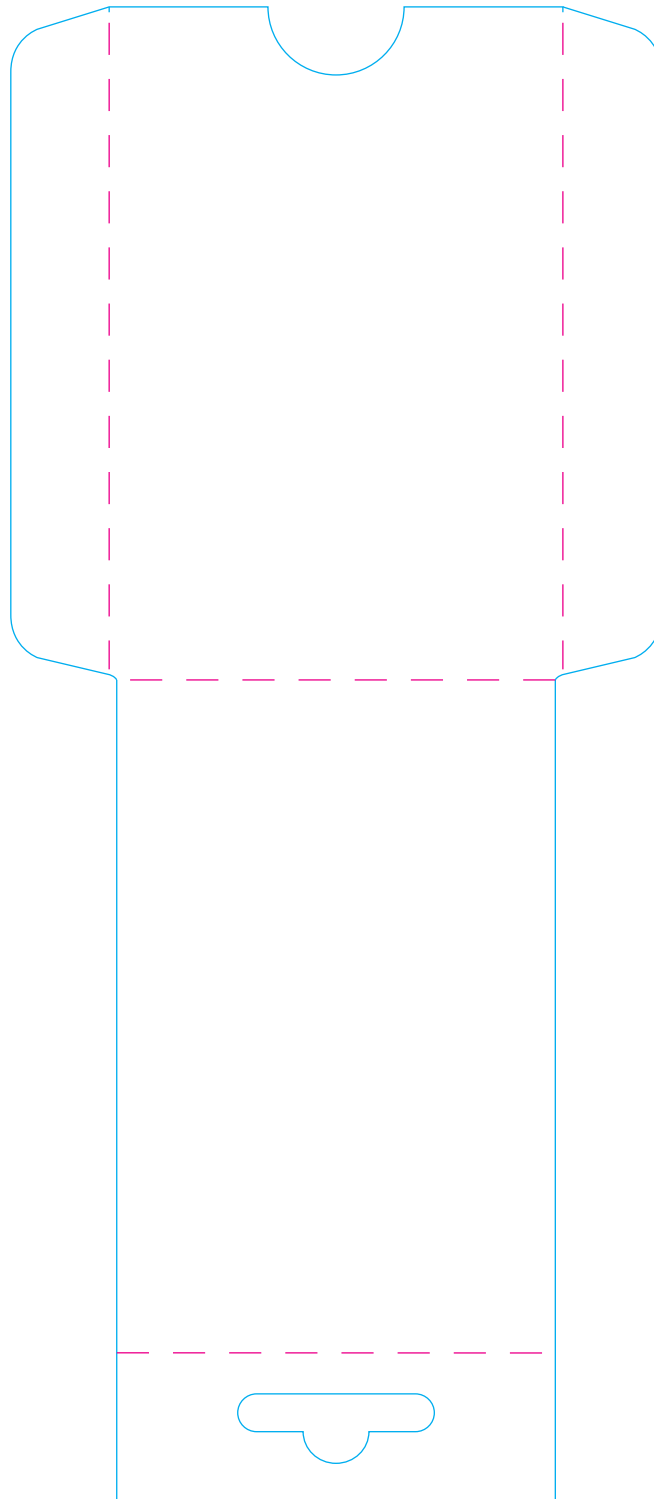

1.1 HOLDERS

1.1.1 Model 01



DIMENSION OF ASSEMBLED HOLDER		DIMENSION OF PREPARATION WITHOUT BLEED		Bleed
width	height	width	height	
62 mm	110 mm	143.5 mm	129.5 mm	It is necessary to leave 3 mm ON ALL SIDES

1.1 HOLDERS

1.1.2 Model 02

Outside tool

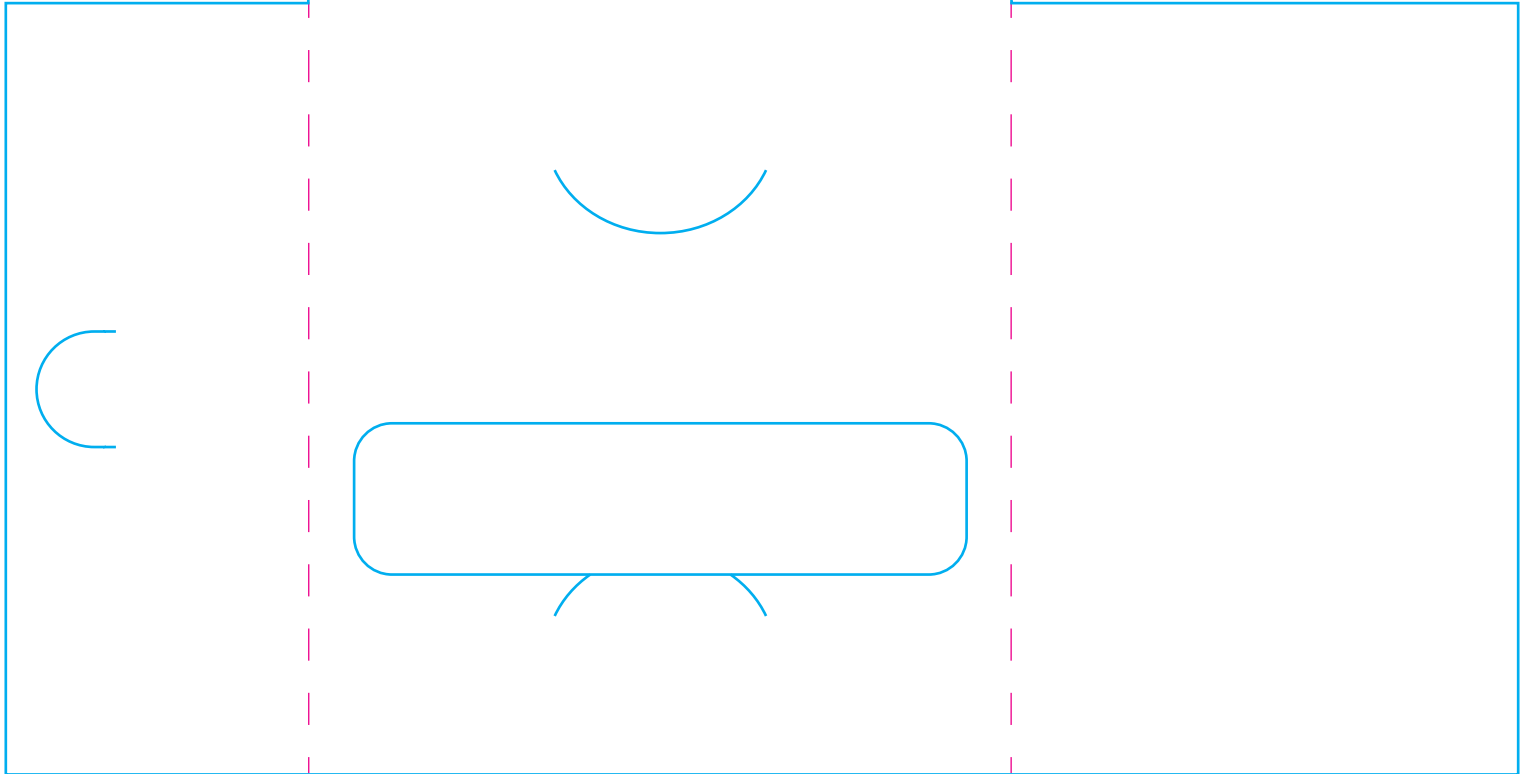

LEGEND

- Cutting ———
- Creasing - - - - -
- Perforation ·····

Inside tool

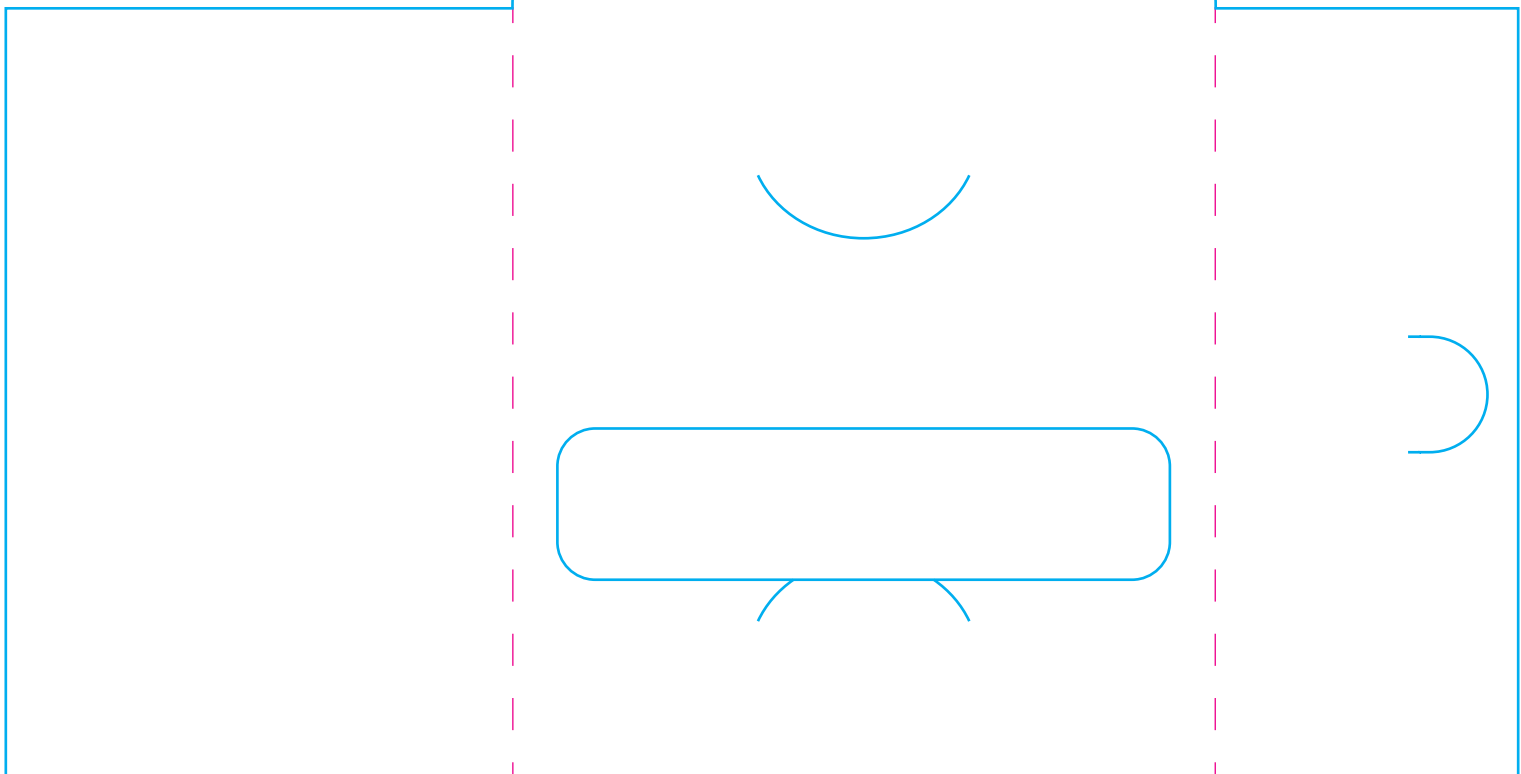

1.1 HOLDERS

1.1.2 Model 02



DIMENSION OF ASSEMBLED HOLDER		DIMENSION OF PREPARATION WITHOUT BLEED		Bleed
width	height	width	height	
93 mm	139 mm	200 mm	139 mm	It is necessary to leave 3 mm ON ALL SIDES

1.1 HOLDERS

1.1.3 Model 03

LEGEND

- Cutting ———
- Creasing - - - - -
- Perforation ·····

Outside tool

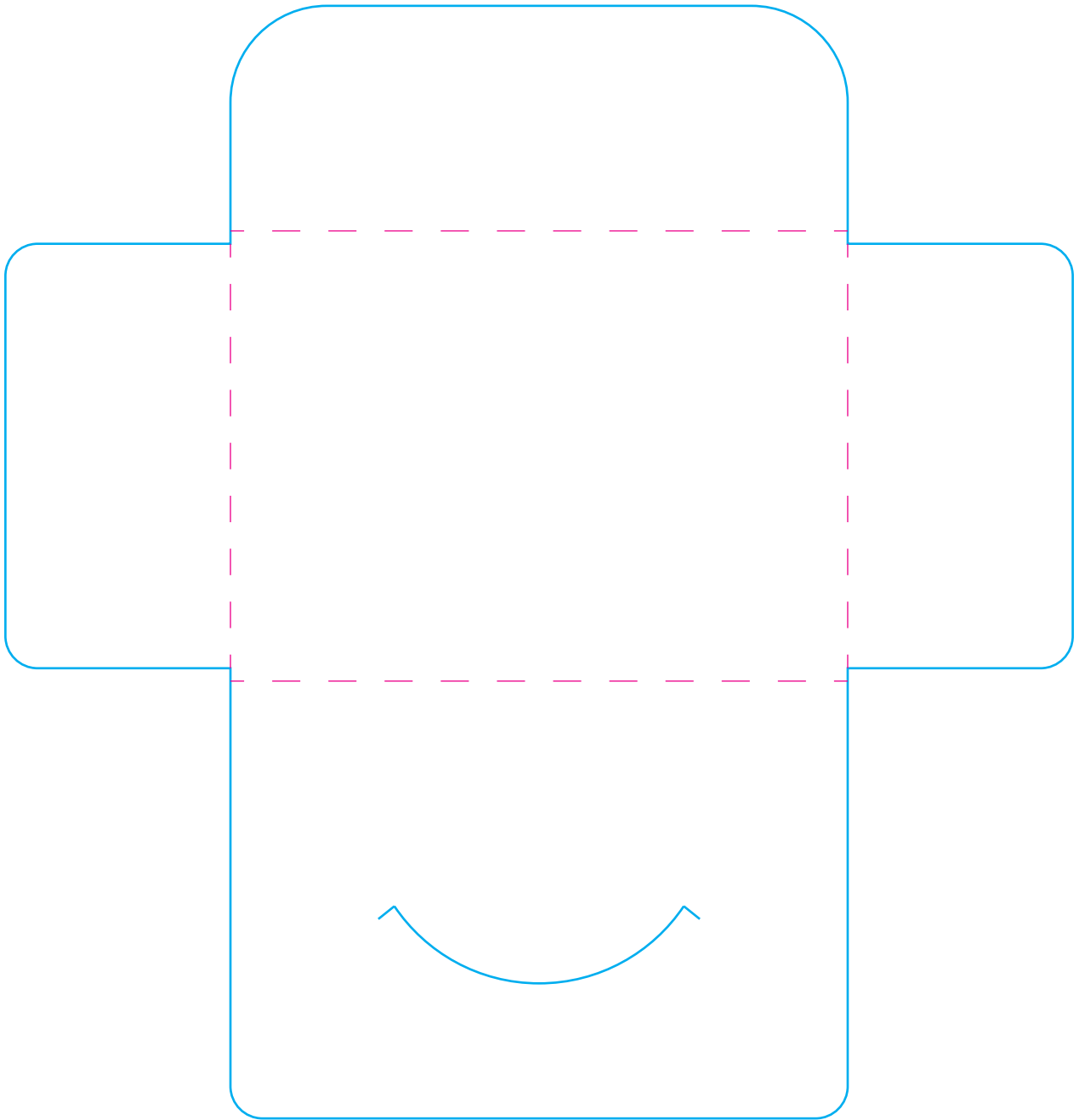

1.1 HOLDERS

1.1.3 Model 03

LEGEND

- Cutting ———
- Creasing - - - - -
- Perforation ·····

Inside tool

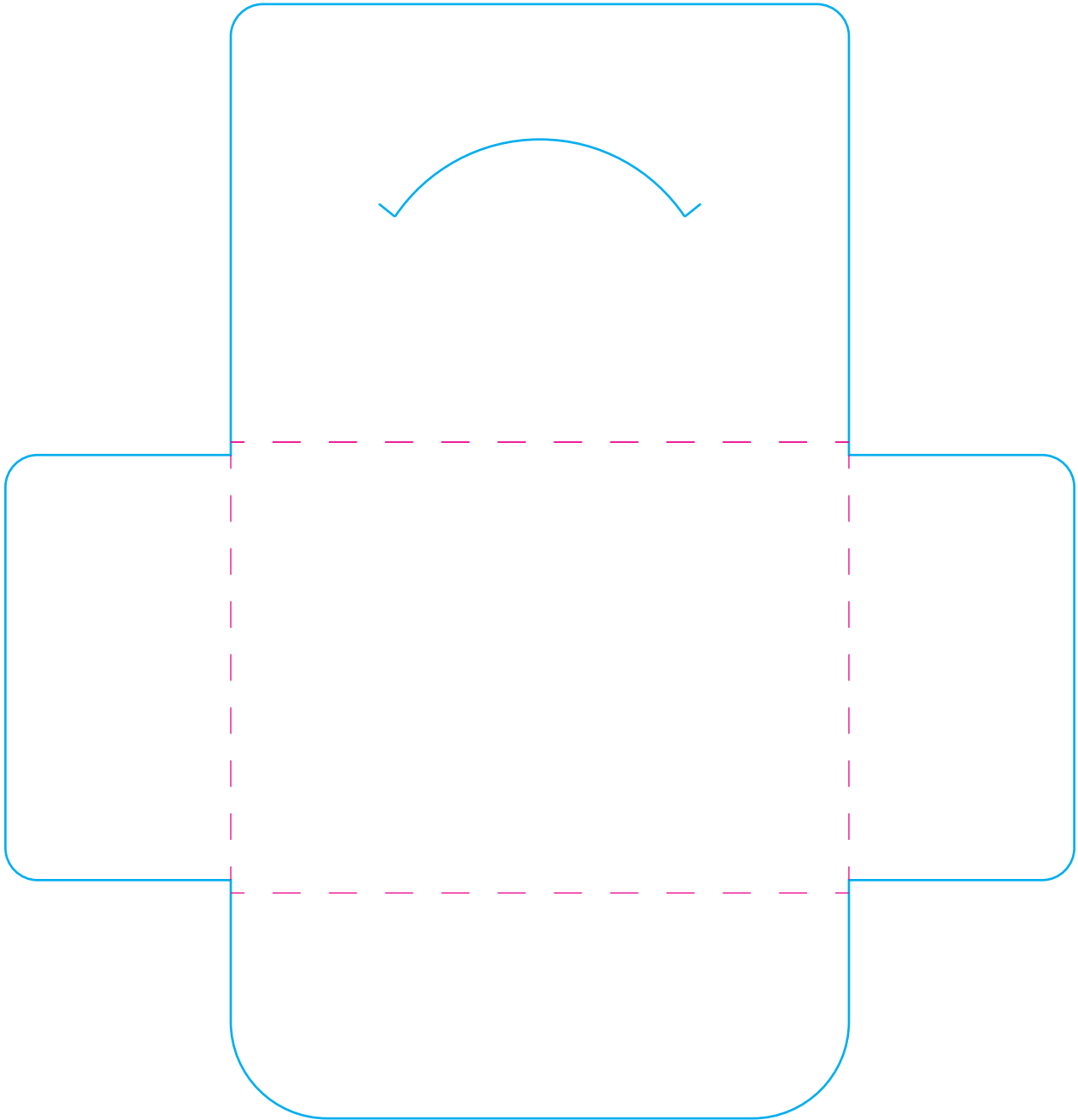

1.1 HOLDERS

1.1.3 Model 03



DIMENSION OF ASSEMBLED HOLDER		DIMENSION OF PREPARATION WITHOUT BLEED		Bleed
width	height	width	height	
96 mm	70 mm	172 mm	179 mm	It is necessary to leave 3 mm ON ALL SIDES

1.1 HOLDERS

1.1.4 Model 06

LEGEND

- Cutting ———
- Creasing - - - - -
- Perforation - · - · -

Outside tool

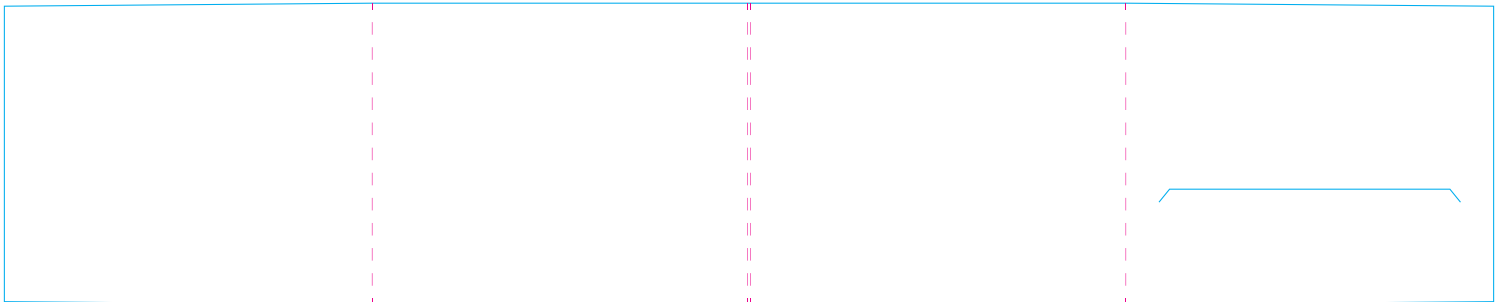

Inside tool

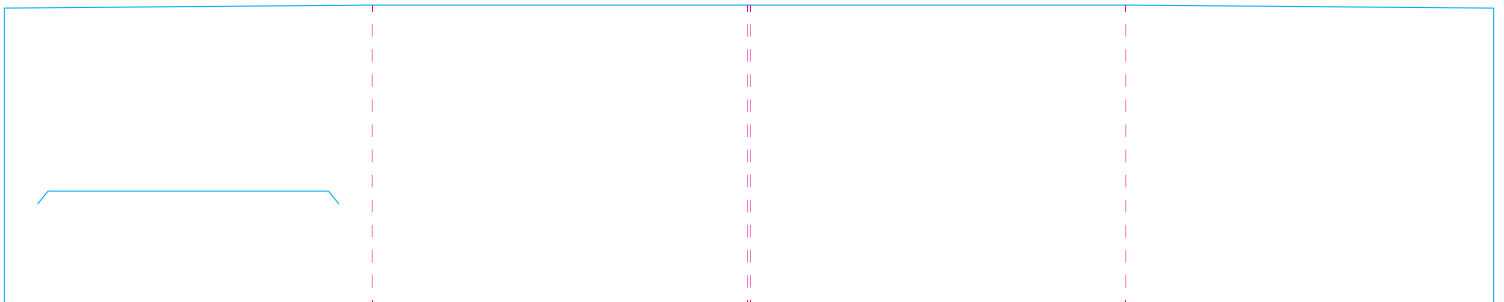

A Tool is not the right dimension, it has been zoomed out proportionally to fit A4 format. So, when you do the preparation, you need to zoom in the tool proportionally in accordance with the specification on the next page for Model 06.

1.1 HOLDERS

1.1.4 Model 06



DIMENSION OF ASSEMBLED HOLDER		DIMENSION OF PREPARATION WITHOUT BLEED		Bleed
width	height	width	height	
122 mm	99 mm	494 mm	98 mm	It is necessary to leave 3 mm ON ALL SIDES

1.1 HOLDERS

1.1.5 Model 10

LEGEND

- Cutting 
- Creasing 
- Perforation 

Outside tool

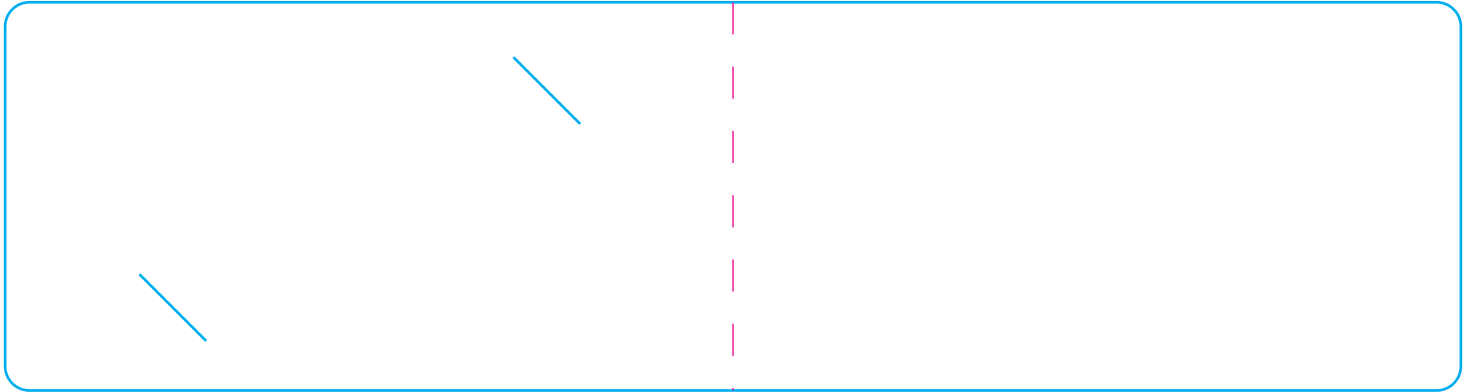

Inside tool

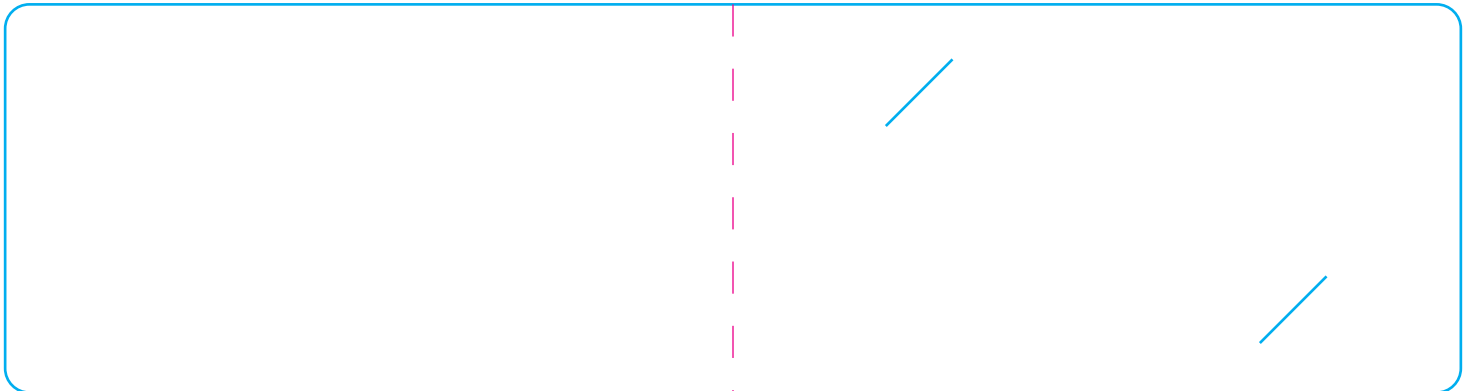

A Tool is not the right dimension, it has been zoomed out proportionally to fit A4 format. So, when you do the preparation, you need to zoom in the tool proportionally in accordance with the specification on the next page for Model 10.

1.1 HOLDERS

1.1.5 Model 10

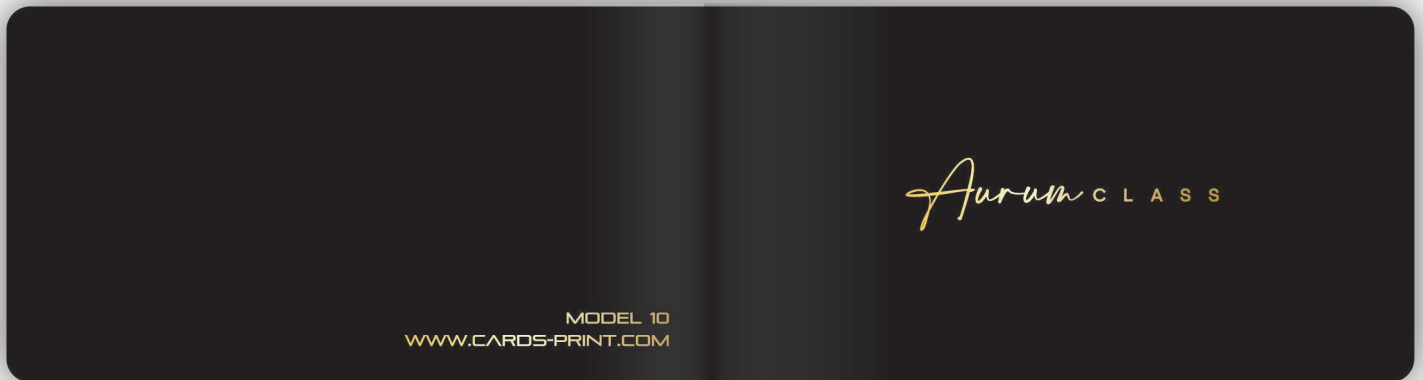

DIMENSION OF ASSEMBLED HOLDER		DIMENSION OF PREPARATION WITHOUT BLEED		Bleed
width	height	width	height	
150 mm	80 mm	300 mm	90 mm	It is necessary to leave 3 mm ON ALL SIDES

1.1 HOLDERS

1.1.6 Model 13

LEGEND

- Cutting ———
- Creasing - - - - -
- Perforation ·····

Outside tool

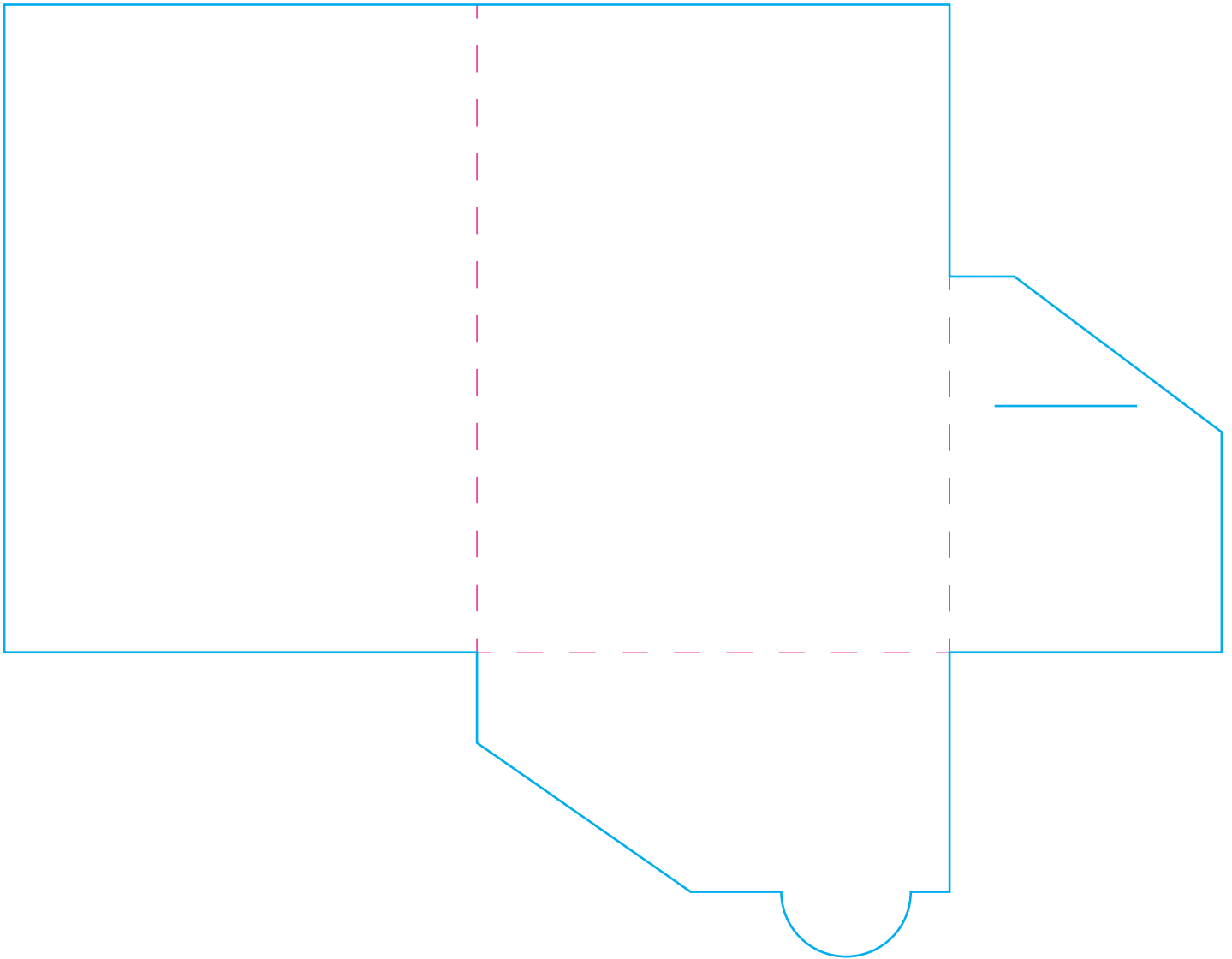

1.1 HOLDERS

1.1.6 Model 13

LEGEND

- Cutting ———
- Creasing - - - - -
- Perforation ·····

Inside tool

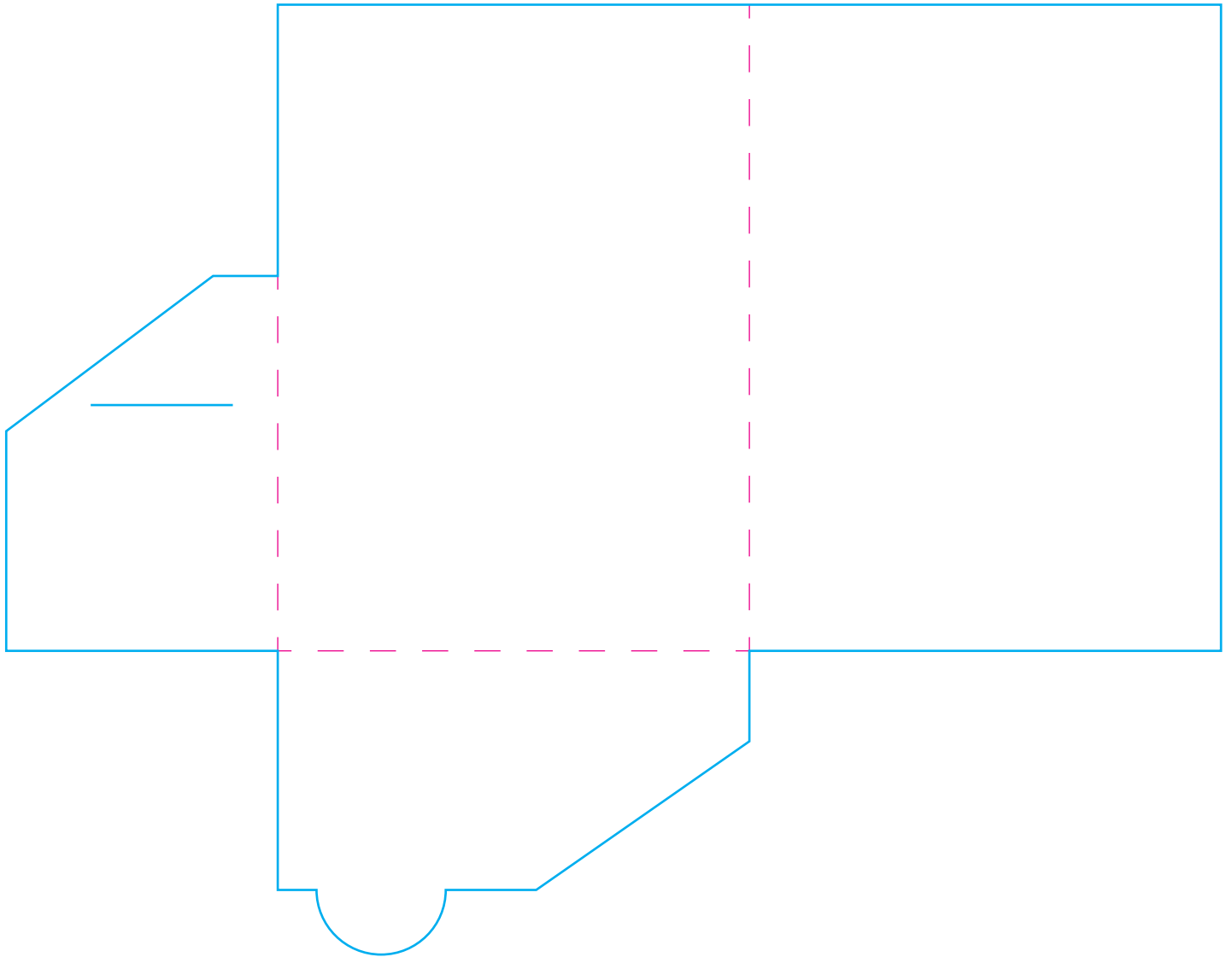

1.1 HOLDERS

1.1.6 Model 13

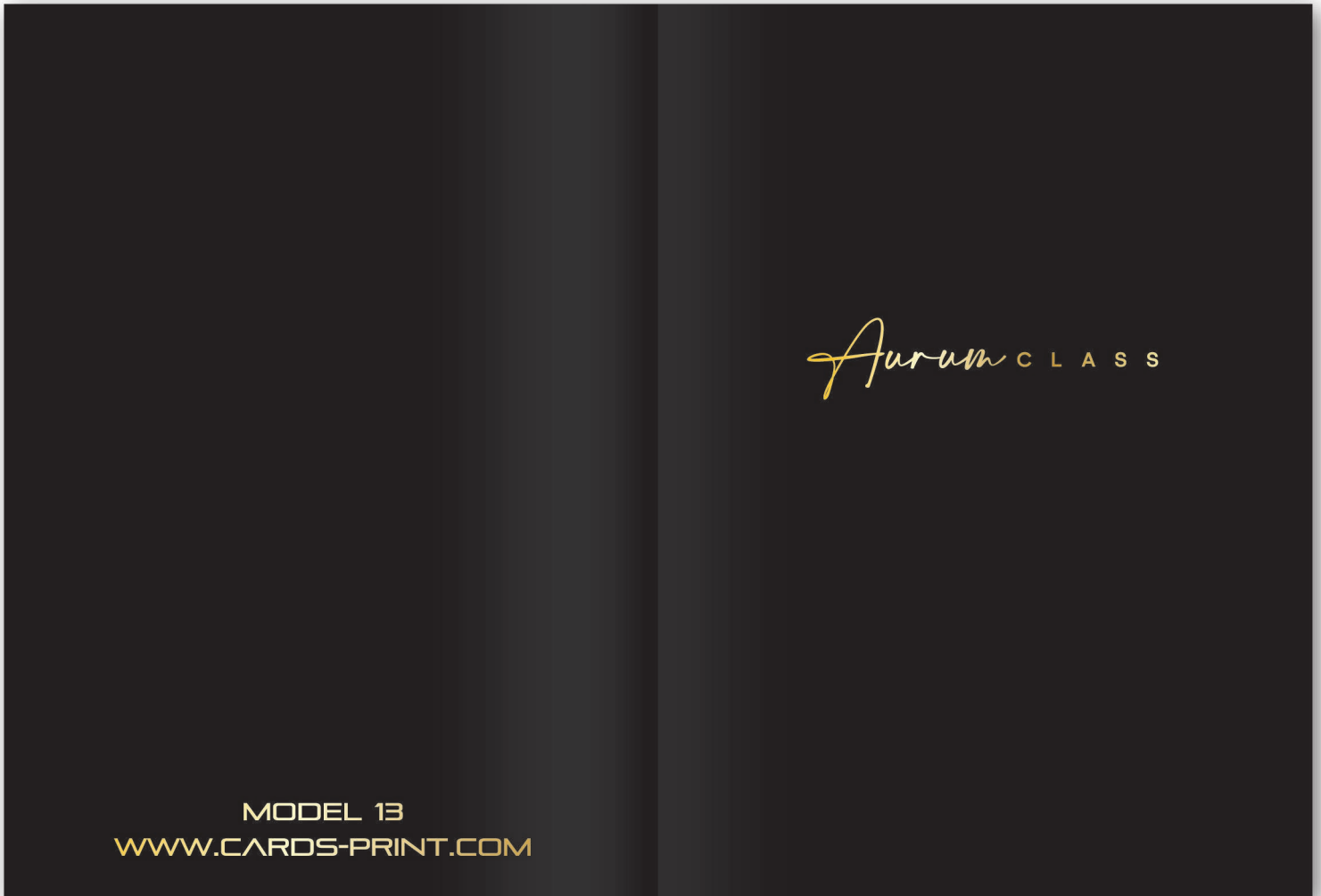

DIMENSION OF ASSEMBLED HOLDER		DIMENSION OF PREPARATION WITHOUT BLEED		Bleed
width	height	width	height	
73 mm	100 mm	188 mm	147 mm	It is necessary to leave 3 mm ON ALL SIDES

1.1 HOLDERS

1.1.7 Model 15

LEGEND

- Cutting ———
- Creasing - - - - -
- Perforation ·····

Outside and inside tools

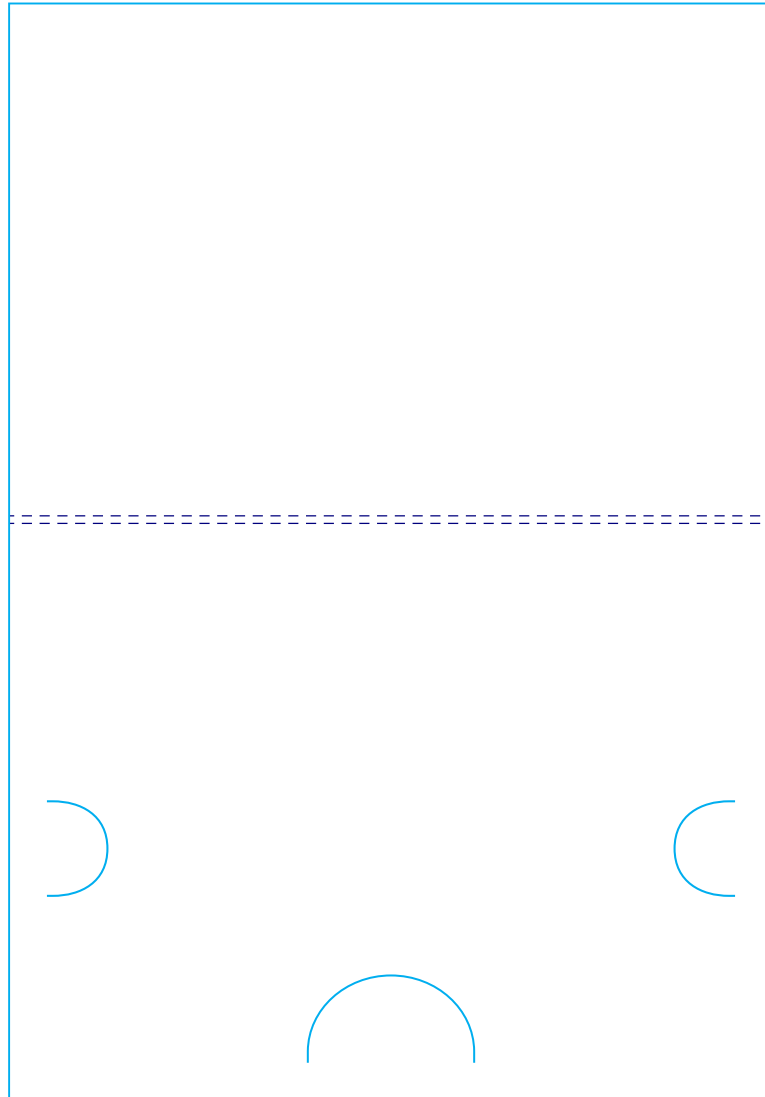

1.1 HOLDERS

1.1.7 Model 15



DIMENSION OF ASSEMBLED HOLDER		DIMENSION OF PREPARATION WITHOUT BLEED		Bleed
width	height	width	height	
101 mm	77 mm	101 mm	145 mm	It is necessary to leave 3 mm ON ALL SIDES

1.1 HOLDERS

1.1.8 Model 16

Outside tool

LEGEND

- Cutting ———
- Creasing - - - - -
- Perforation ·····

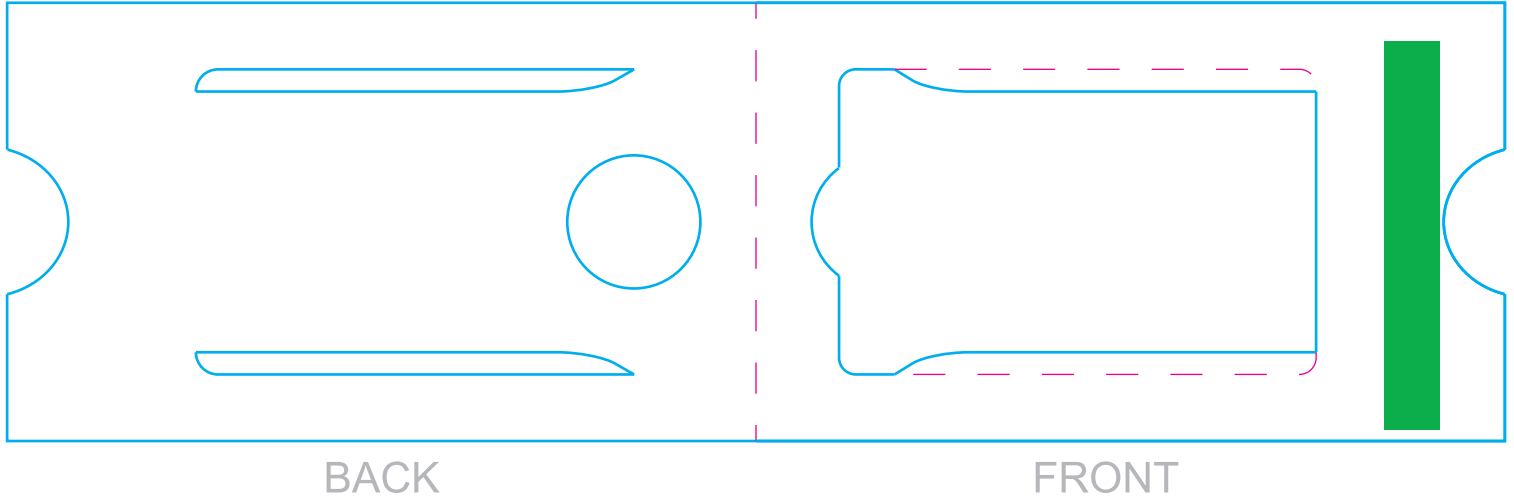

Inside tool

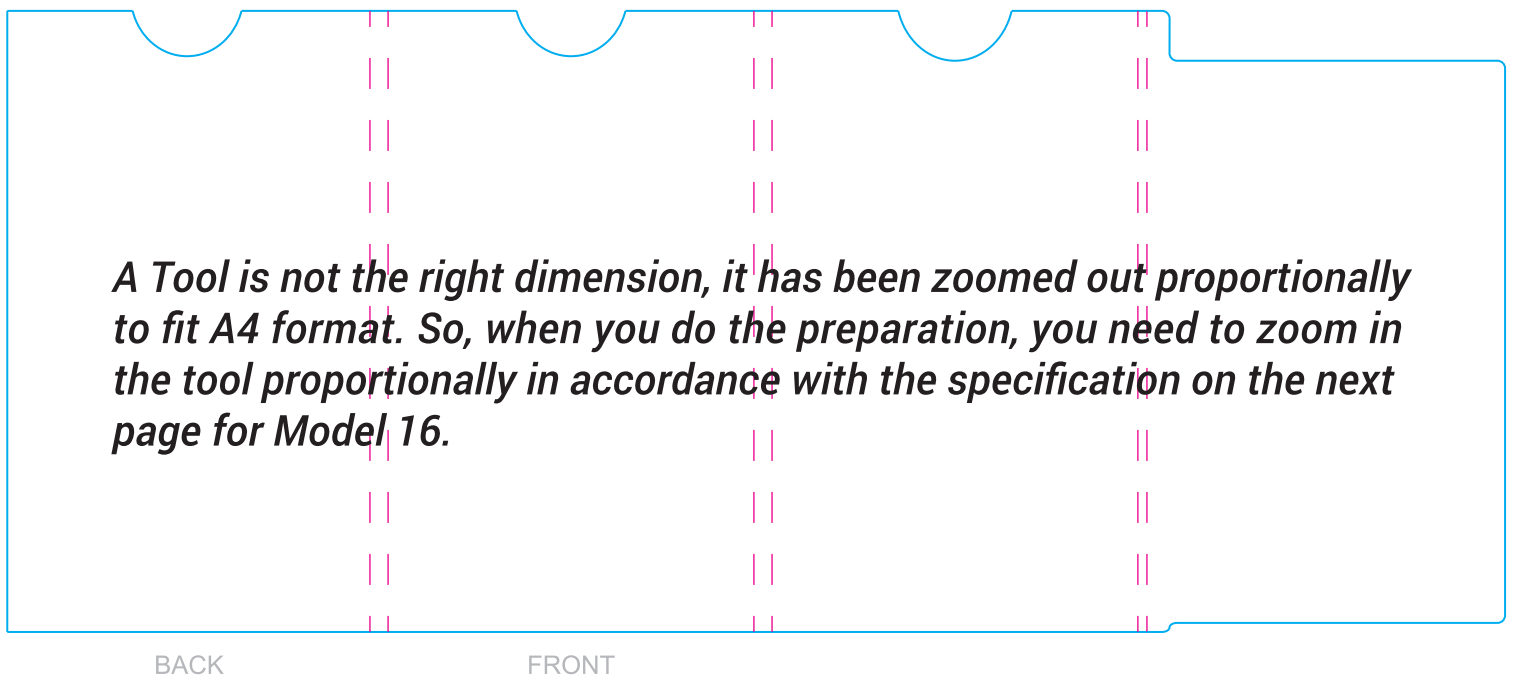
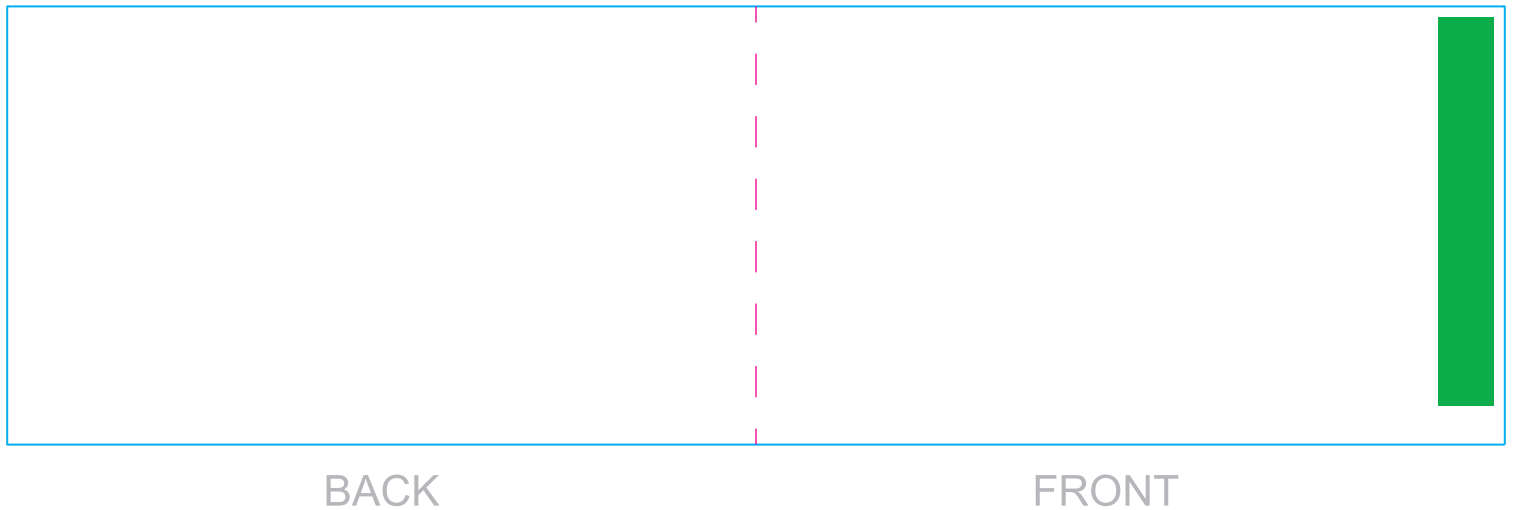

A Tool is not the right dimension, it has been zoomed out proportionally to fit A4 format. So, when you do the preparation, you need to zoom in the tool proportionally in accordance with the specification on the next page for Model 16.

1.1 HOLDERS

1.1.8 Model 16



DIMENSION OF ASSEMBLED HOLDER		DIMENSION OF PREPARATION OF THE CENTRAL PART WITHOUT BLEED		Bleed
width	height	width	height	
135 mm	79 mm	270 mm	79 mm	It is necessary to leave 3 mm ON ALL SIDES
		DIMENSION OF PREPARATION OF THE WORK TO BE DRAWN WITHOUT BLEED		
		330 mm	137 mm	

1.1 HOLDERS

1.1.9 Model MK 01

Outside tool

LEGEND

- Cutting 
- Creasing 
- Perforation 

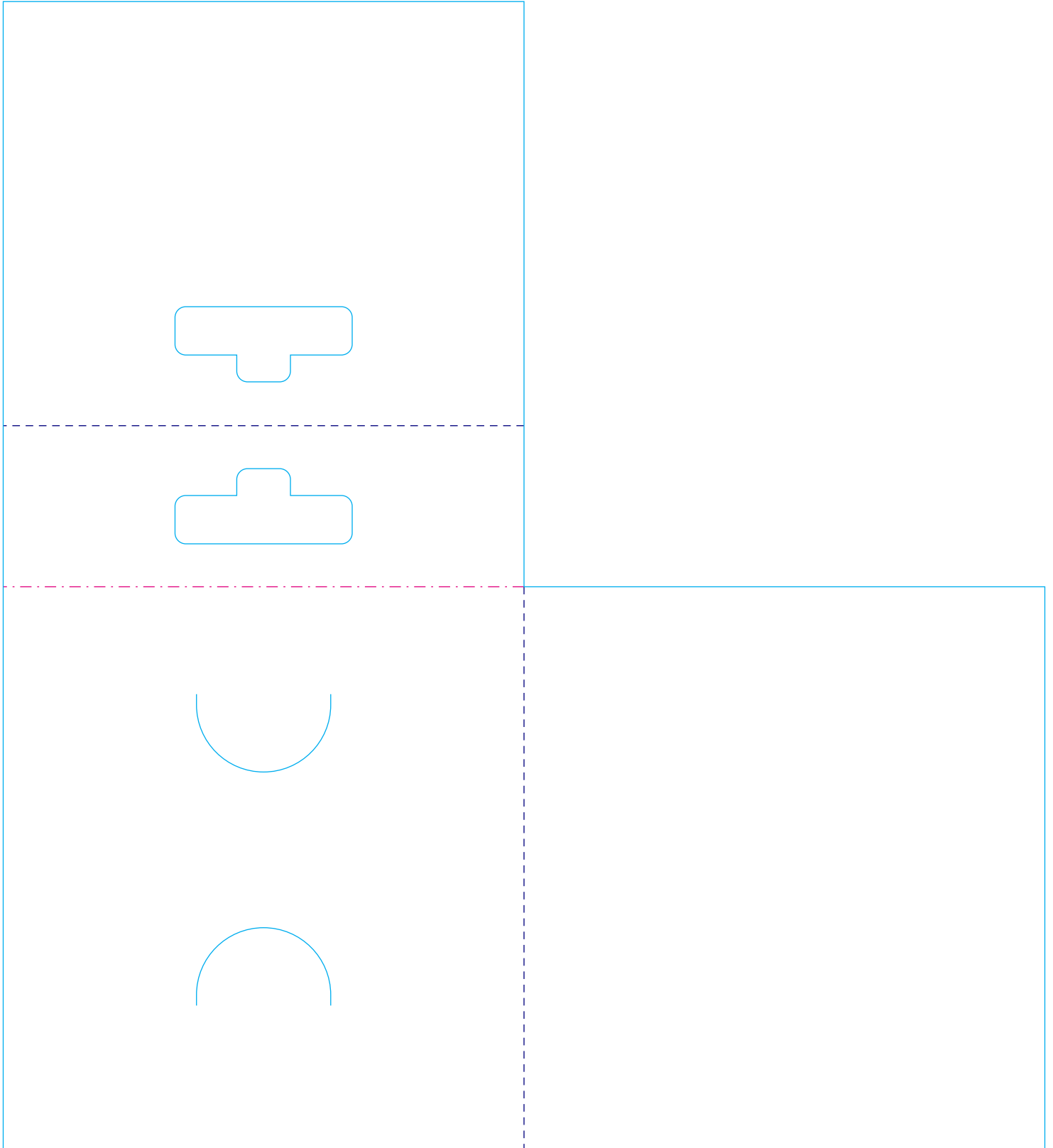

1.1 HOLDERS

1.1.9 Model MK 01

Inside tool

LEGEND

- Cutting ———
- Creasing - - - - -
- Perforation - · - · -

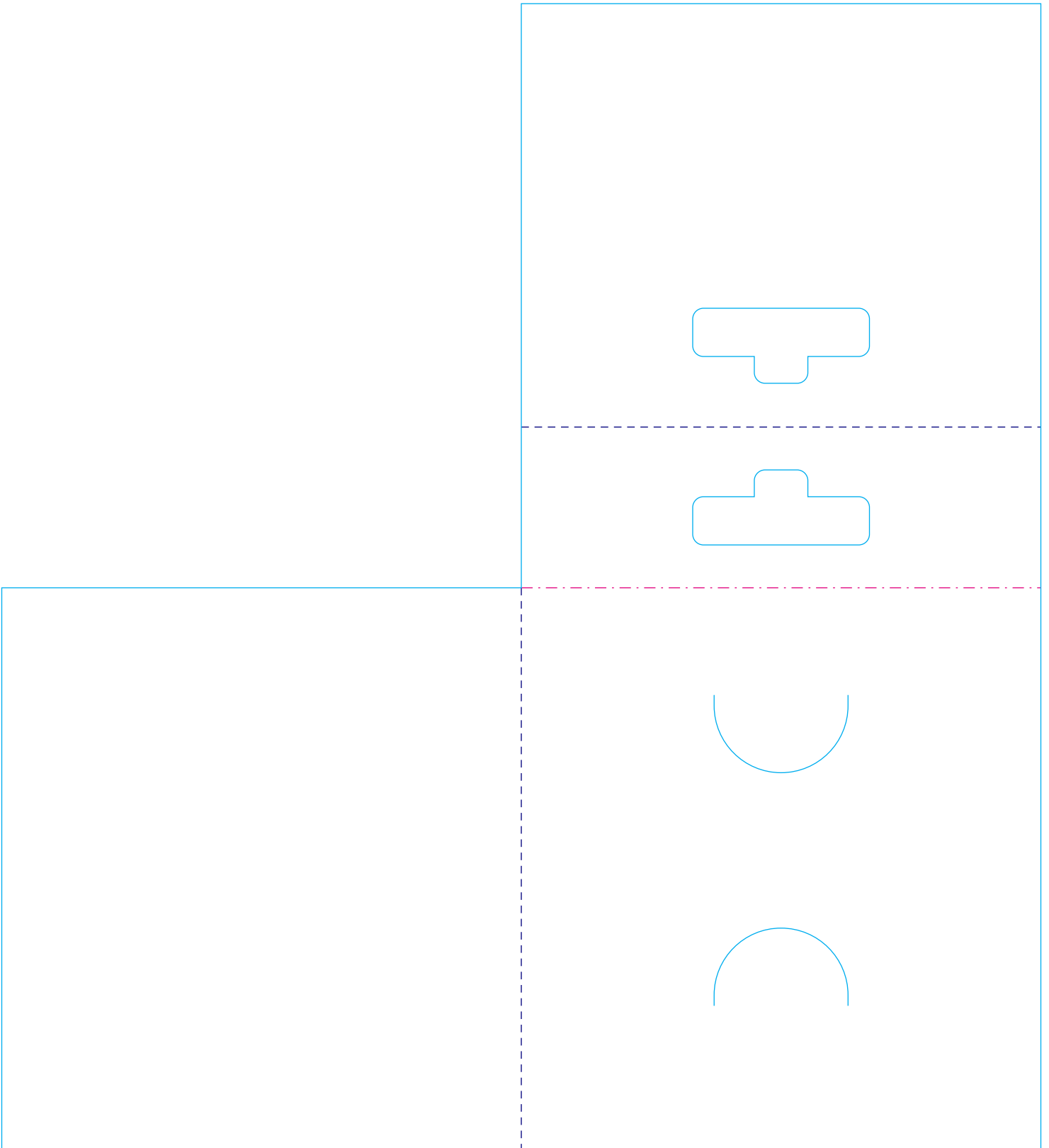

1.1 HOLDERS

1.1.9 Model MK 01



DIMENSION OF ASSEMBLED HOLDER		DIMENSION OF PREPARATION WITHOUT BLEED		Bleed
width	height	width	height	
97 mm	134 mm	194 mm	214 mm	It is necessary to leave 3 mm ON ALL SIDES

1.1 HOLDERS

1.1.10 Model MK 02

Outside and inside tools

LEGEND

Cutting ———
Creasing - - - - -
Perforation ·····

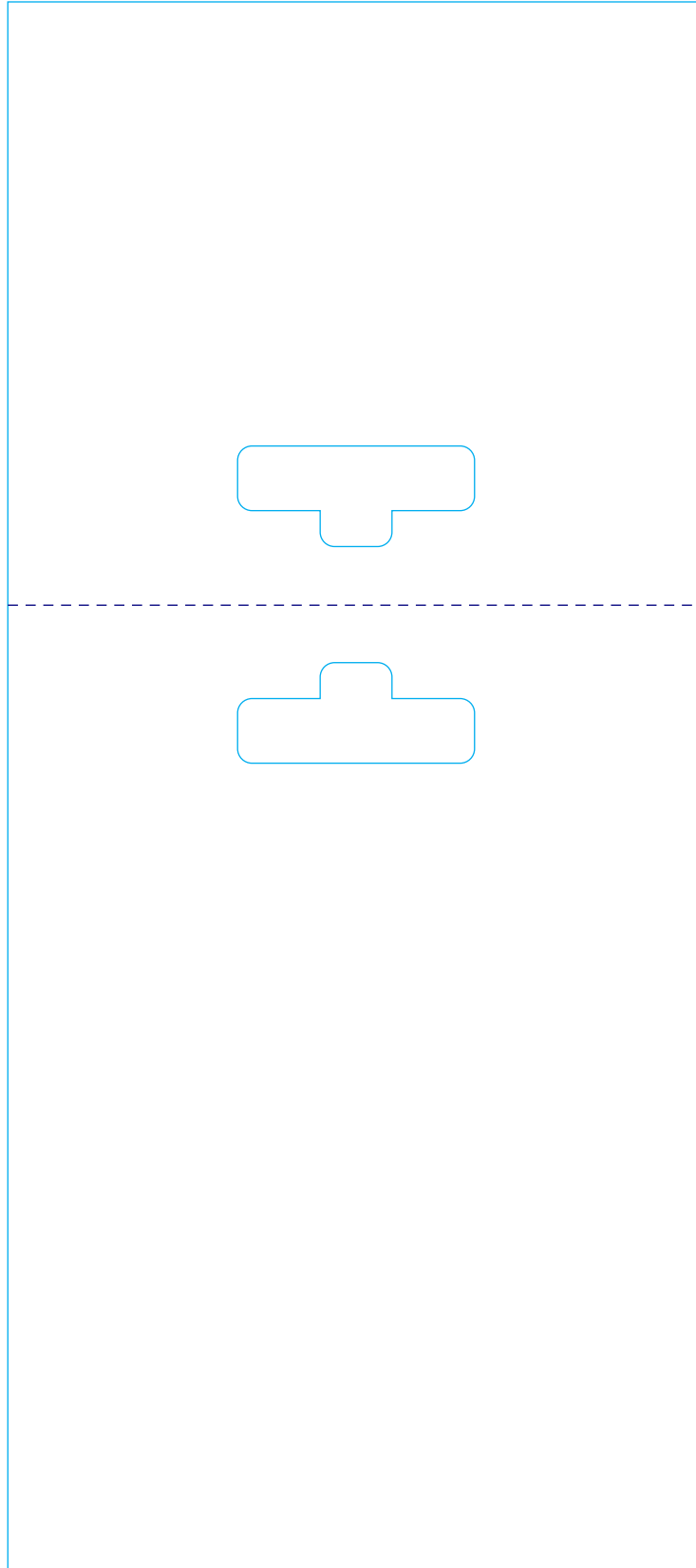

1.1 HOLDERS

1.1.10 Model MK 02

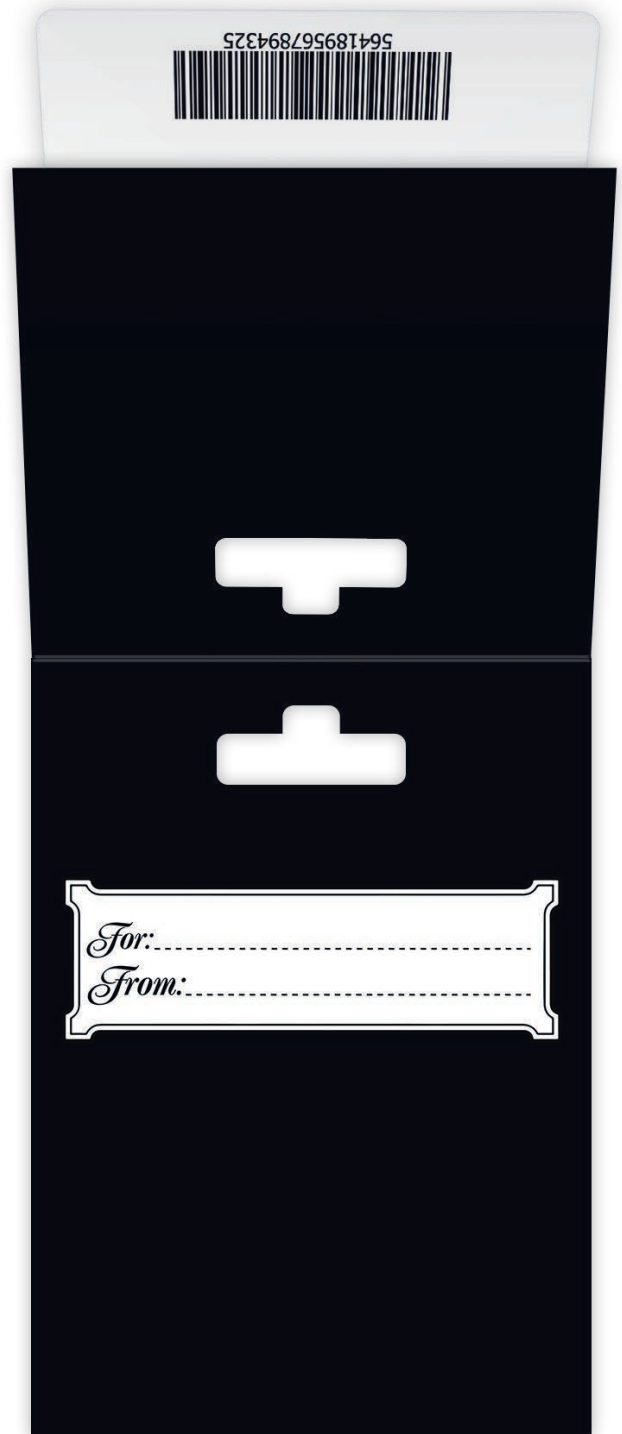
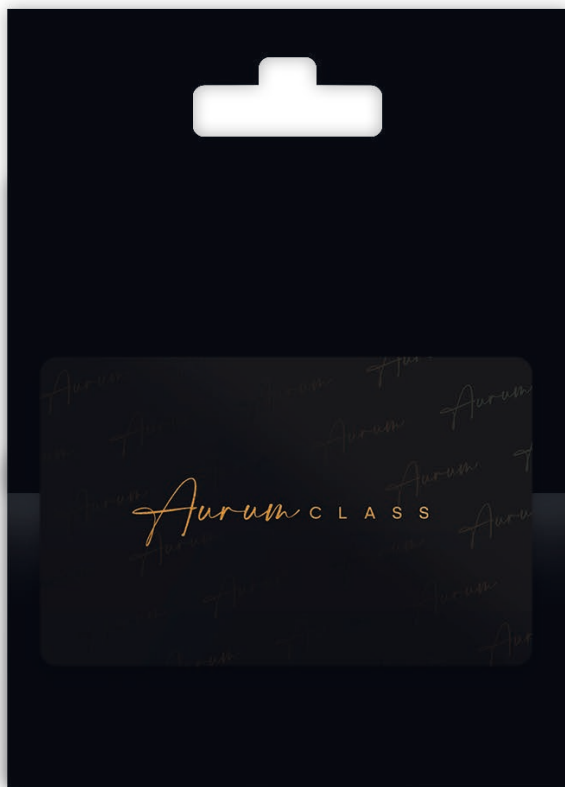

DIMENSION OF ASSEMBLED HOLDER		DIMENSION OF PREPARATION WITHOUT BLEED		Bleed
width	height	width	height	
97 mm	134 mm	97 mm	219 mm	It is necessary to leave 3 mm ON ALL SIDES

1.1 HOLDERS

1.1.11 Model MK 03

Outside and inside tools

LEGEND

Cutting ———
Creasing - - - - -
Perforation ·····

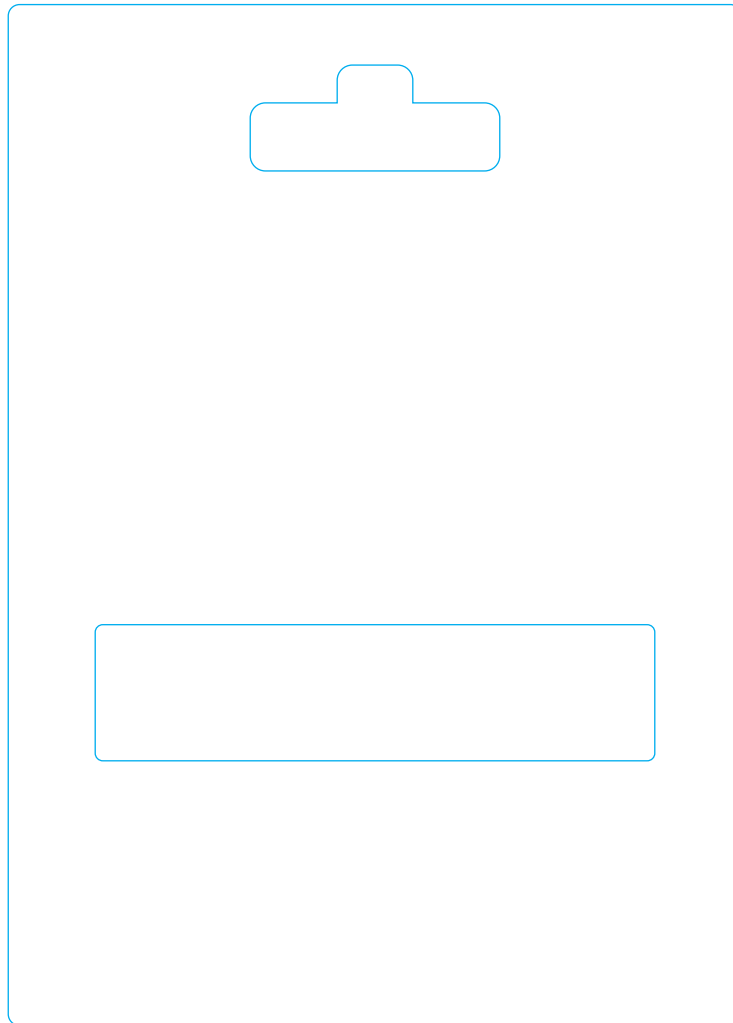

1.1 HOLDERS

1.1.11 Model MK 03

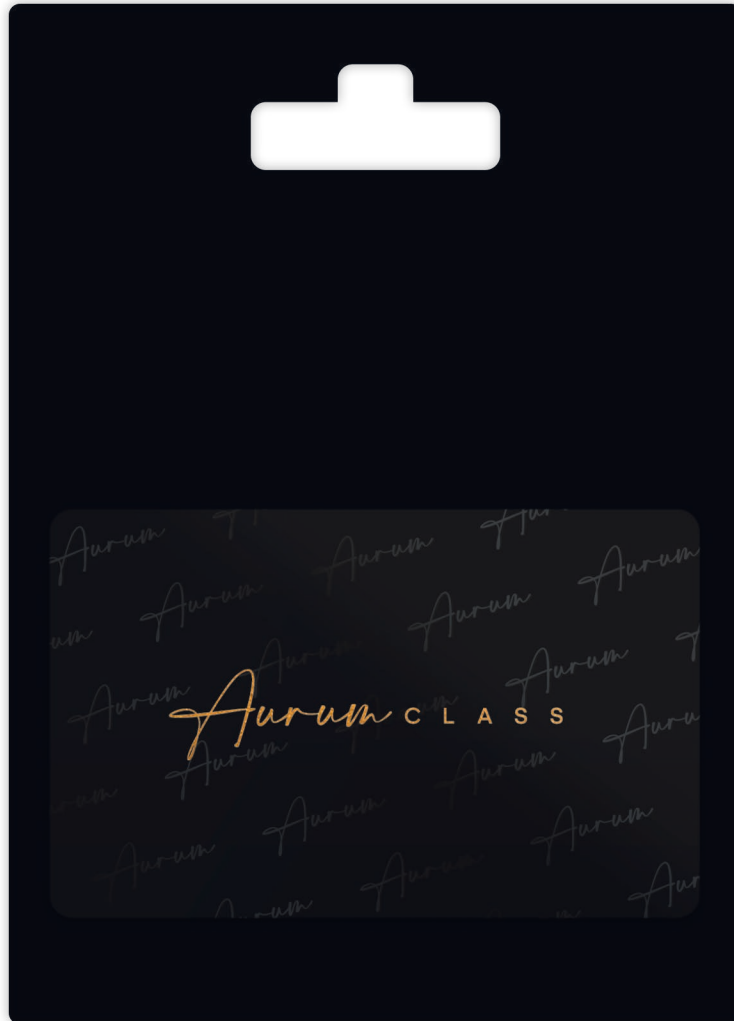

DIMENSION OF ASSEMBLED HOLDER		DIMENSION OF PREPARATION WITHOUT BLEED		Bleed
width	height	width	height	
97 mm	135 mm	97 mm	135 mm	It is necessary to leave 3 mm ON ALL SIDES

1.1 HOLDERS

1.1.12 Model MK 05

Outside and inside tools

LEGEND

Cutting ———
Creasing - - - - -
Perforation ·····

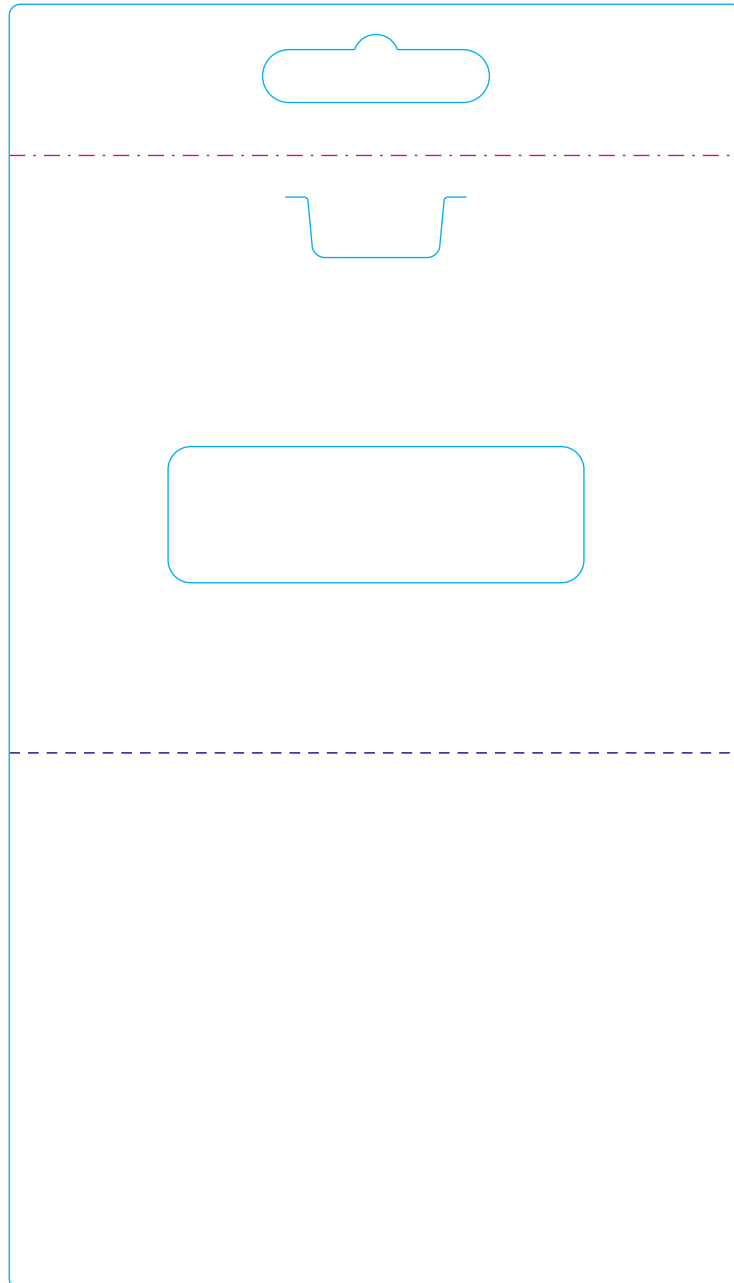

1.1 HOLDERS

1.1.12 Model MK 05

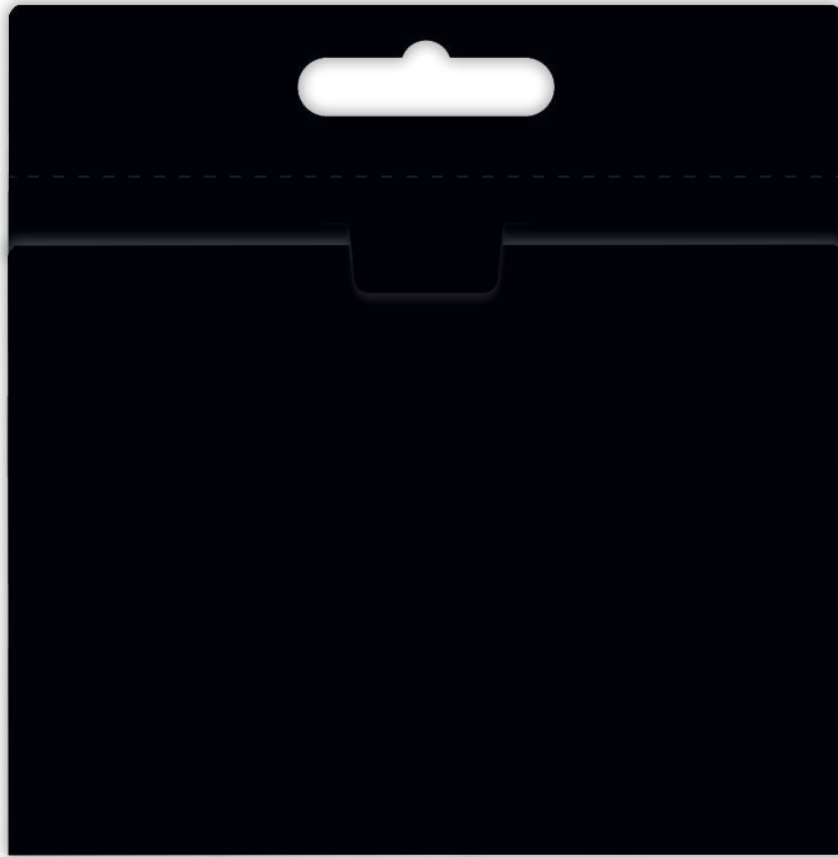

DIMENSION OF ASSEMBLED HOLDER		DIMENSION OF PREPARATION WITHOUT BLEED		Bleed
width	height	width	height	
97 mm	98 mm	97 mm	170 mm	It is necessary to leave 3 mm ON ALL SIDES

1.2 APPLICATION FORMS

1.2.1 Model 01

Outside tool

LEGEND

Cutting ———
Creasing - - - -
Perforation - · - · -



Inside tool

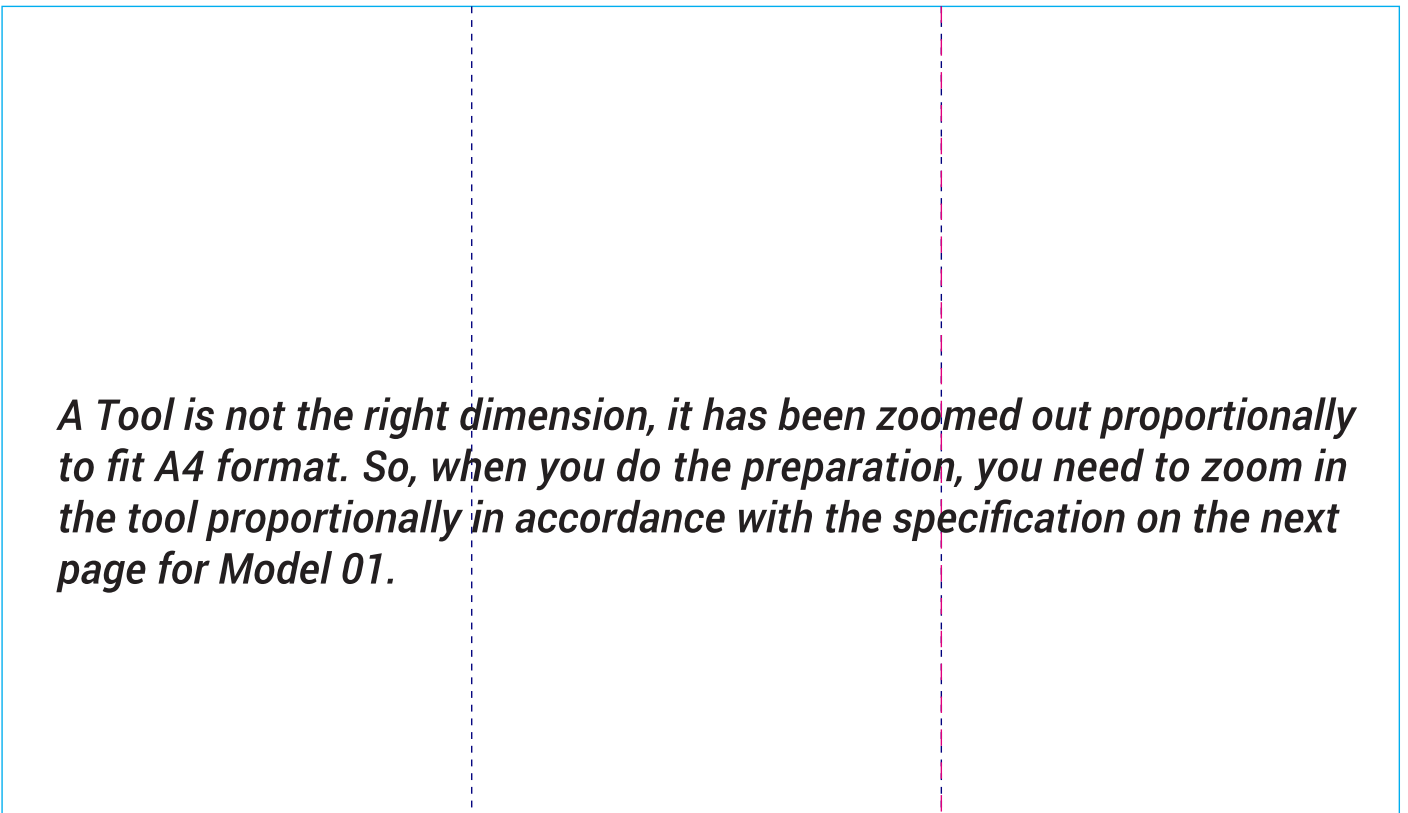

1.2 APPLICATION FORMS

1.2.1 Model 01



DIMENSION OF ASSEMBLED APPLICATION FORM		DIMENSION OF PREPARATION WITHOUT BLEED		Bleed
width	height	width	height	
118 mm	210 mm	360 mm	210 mm	It is necessary to leave 3 mm ON ALL SIDES

1.2 APPLICATION FORMS

1.2.2 Model 02

LEGEND

- Cutting 
- Creasing 
- Perforation 

Outside tool

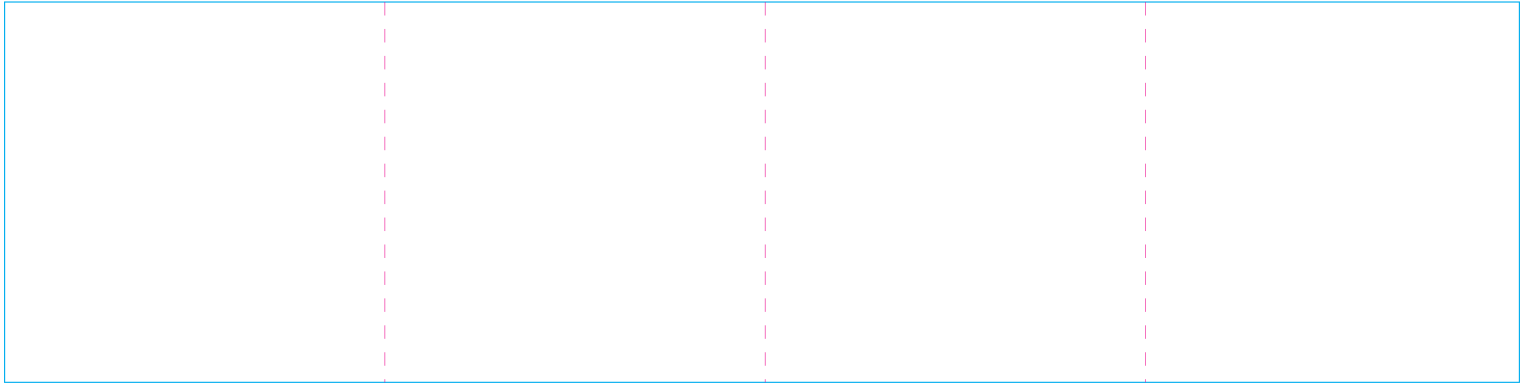

Inside tool

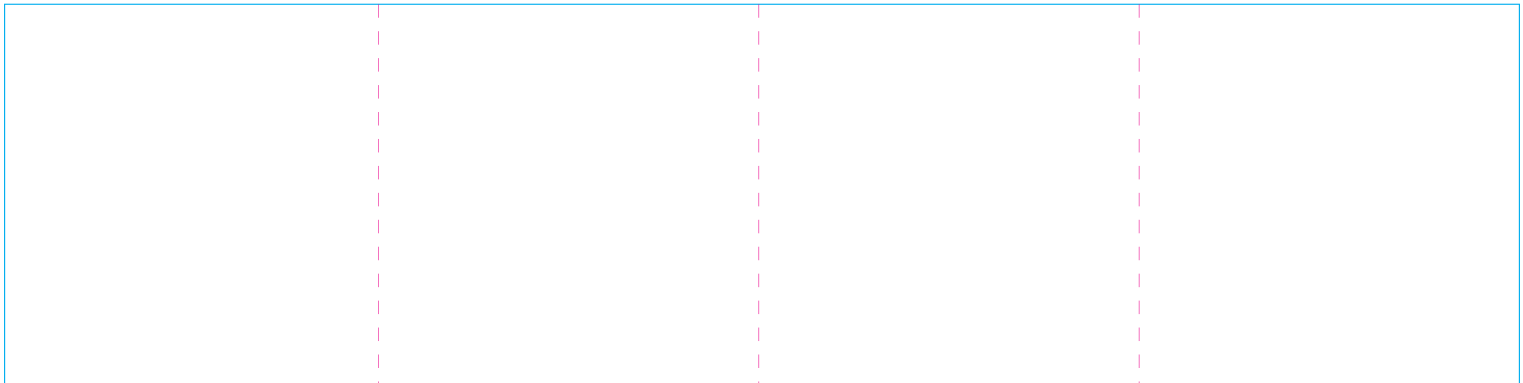

A Tool is not the right dimension, it has been zoomed out proportionally to fit A4 format. So, when you do the preparation, you need to zoom in the tool proportionally in accordance with the specification on the next page for Model 02.

1.2 APPLICATION FORMS

1.2.2 Model 02



DIMENSION OF ASSEMBLED APPLICATION FORM		DIMENSION OF PREPARATION WITHOUT BLEED		Bleed
width	height	width	height	
118 mm	120 mm	478 mm	120 mm	It is necessary to leave 3 mm ON ALL SIDES

1.2 APPLICATION FORMS

1.2.3 Model 03

LEGEND

Cutting	
Creasing	
Perforation	

Outside and inside tools

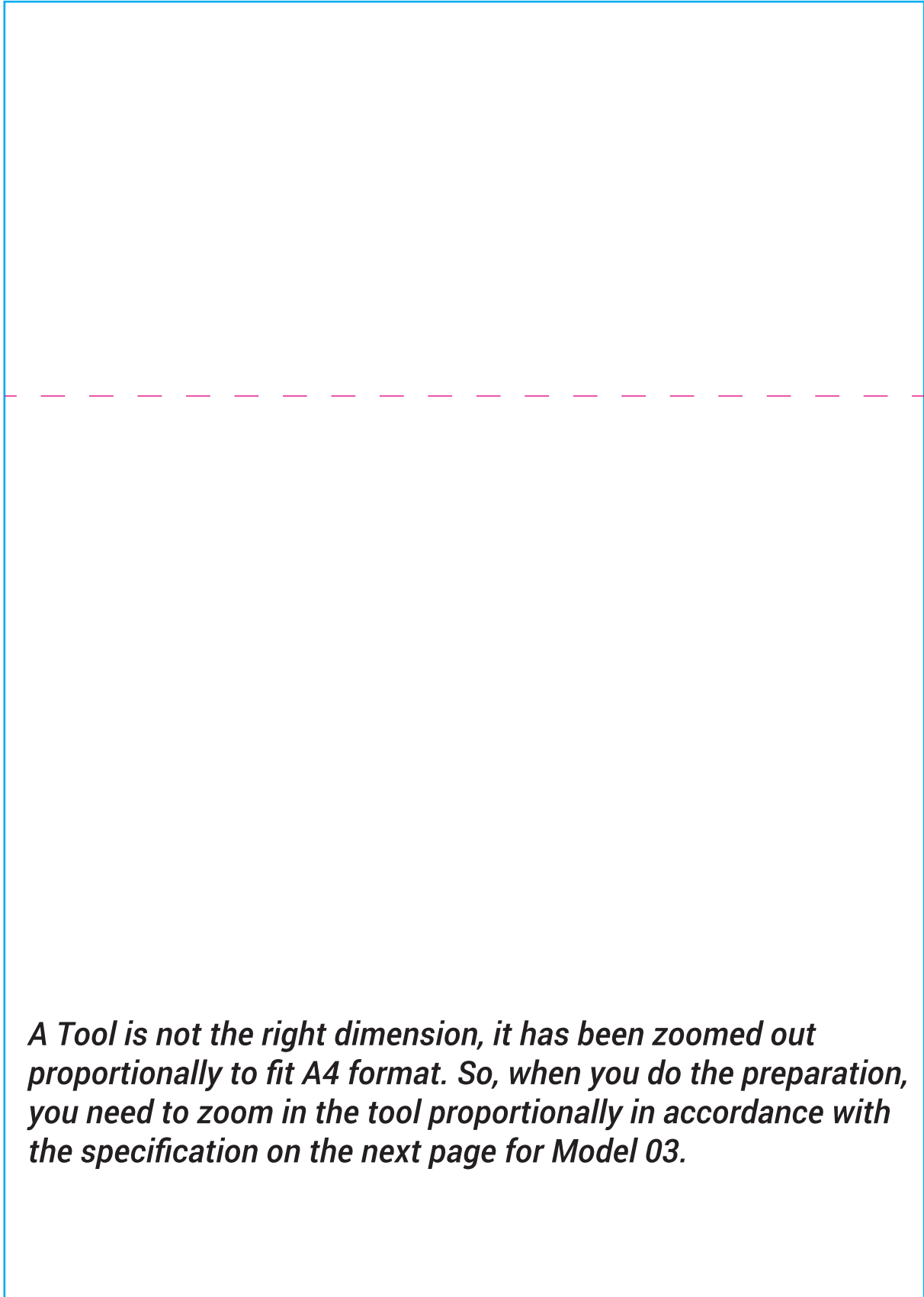

1.2 APPLICATION FORMS

1.2.3 Model 03

PREDNJA STRANA

ZADNJA STRANA



MODEL NO 03

PRISTUPNICA



THE PLASTIC CARD SPECIALISTS

OBRAZAC PRIJAVE ZA KARTICU LOJALNOSTI

MOLIMO POPUNITE TRAŽENE PODATKE VELIKIM SLOVIMA.

Ime*: _____

Prezime*: _____

Pol*: M Ž

Ulica i broj: _____

Poštanski broj*: _____

Grad*: _____

Država / Pokrajina: _____

Zemlja*: _____

Broj mobilnog telefona*: _____

E-mail*: _____

Datum rođenja* (d/m/gg): _____

Želim da se registrujem za kupovinu putem Interneta na adresi www.cardsprint.rs i da mi se akreditiraju korisnika šaljku na moju ulicu ili adresu e-pošte:

DA NE

IZJAVA

Ja, niže potpisano Lice izjavljujem da mi je unučena kartica lojalnosti kao i da sam pročitao i razumeo Obaveštenje sa ove pristupnice, te ovim putem izjavljujem sledeće:

- da sam saglasan da moje lične podatke koje dostavljam Rukovalocu u skladu sa Obaveštenjem, Rukovalac obrađuje i koristi u skladu s odredbama iz Obaveštenja i odredbama važećeg Zakona o zaštiti podataka o ličnosti;
- da svoje podatke o ličnosti dajem dobrovoljno;
- da Rukovalac podataka koje navedene podatke može da prikuplja i skladišti posredstvom softverskog sistema i da ih koristi u svrhu realizacije Programa Lojalnosti, kao i u svrhu navedenu u Obaveštenju, uključujući direktni marketing, profilisanje, statističku obradu i komunikaciju sa mnom;
- da ću za ostvarenje svojih prava koja mi pripadaju (uključujući i pravo na opoziv pristanka) prvenstveno kontaktirati Rukovalca putem nekog od kontakata navedenog u Obaveštenju;

U _____ Dana _____ Ime i prezime davoca izjave _____ Svojeručni potpis davoca izjave _____



BARKOD NALEPNICA



T. +381 11 41 41 540
info@cardsprint.rs
Novosajanski put 38a,
26000 Pan evo, Srbija
www.cardsprint.rs

PRAVILA PROGRAMA LOJALNOSTI

1. Kartica lojalnosti izdaje Cards Print d.o.o. Novosajanski put 38a, 26000 Pan evo. Kartica lojalnosti je vlasništvo davoca kartice.
2. Članstvo u programu lojalnosti je besplatno.
3. Sveka punoletna osoba sa prebivalištem u Republici Srbiji koja je prethodno popunila obrazac za članstvo može postati punopravno upisani član programa lojalnosti i vlasnik kartice.
4. Popunjeni obrazac za prijavu podnosi se na navedenom mestu u Cards Print. Nakon potpisivanja prijave, zaposlenik kompanije Cards Print predaje karticu lojalnosti novom članu.
5. Kartica lojalnosti nije sredstvo plaćanja.
6. Kartica lojalnosti je prenosiva, tako da je mogu koristiti i članovi porodice.
7. Kartica lojalnosti važi od datuma izdavanja.
8. Predstav kartica lojalnosti za kupca je popust u iznosu prikupljenih bodova. Bodovi se oseseju kupovinom na Cards Print.
9. Prikupiti bodove u gotovini, debitnim ili kreditnim karticama (American Express, Visa, Mastercard / Mastercard) za sveukupno 1 000 potrošenih dinara, član ima pravo na 1 poen.
10. Jedan bod vredi 100 dinara.
11. Za prikupljanje bodova nakon registracije potrebna je minimalni iznos kupovine od 1 000 dinara po računu.
12. Prikupljeni bodovi se ne mogu zamisliti za gotovinu.
13. Dostimo stimališmo članove koji obavljaju pojedinačne kupovine veće vrednosti - za kupovinu u vrednosti od najmanje 10 000 dinara, za sveukupno 1 000 potrošenih dinara po članu računa pripada 2 boda.
14. Član je dužan da karticu lojalnosti predloži pre početka plaćanja na prodajnom mestu tako bi u nju zabeležio nove bodove (Bodovi 9, 10, 11, 12 i 13), odnosno radi ostvarenja prava na popust na kupovinu u iznosu prikupljenih bodova.
15. Da biste ostvarili pravo na kupovinu u iznosu prikupljenih bodova, potrebno je prikupiti najmanje 50 bodova.

OBAVEŠTENJE I IZJAVA O SAGLASNOSTI ZA PRIKUPLJANJE, OBRADU I KORIŠĆENJE PODATAKA O LIČNOSTI

OBAVEŠTENJE

U skladu sa Zakonom o zaštiti podataka o ličnosti, oim Program Lojalnosti nije moguće realizovati u slučaju nepoštovanja Obaveštenjem (u daljem tekstu: Obaveštenje) ličnim ličnim pramaćim informacijama u vezi sa obradom podataka o ličnosti (u daljem tekstu: Licu), sa Licu potpisivanjem izjave na osnovu ovog Obaveštenja, ali sa saglasnost da u ovom Obaveštenju, Republika Srbija, M.E. ... PIB: ... je saglasna/Rukovalac podataka (u daljem tekstu: Rukovalac) vrši obradu podataka o ličnosti u cilju realizacije programa lojalnosti „My SportLife“ - putem marketinških aktivnosti, uključujući i direktni marketing, profilisanje (u daljem tekstu: Program Lojalnosti).

1. Rukovalac podataka
Rukovalac podataka je ...
Podatke koji se prikupljaju od Vas koristimo isključivo Rukovalac podataka i Licu sa kojima Rukovalac podataka ima ugovor o obradi podataka, uključivo u svrhu navedenu u ovom Obaveštenju.

2. Kontakt
U vezi sa svim zahtevima koji se odnose na podatke o ličnosti Licu sa moju obradu Rukovalac podataka na neke od sledećih načina: Email: _____
Pozivna adresa: _____
Šifra: +381 _____

3. Kategorije podataka o ličnosti koji se obrađuju su sledeće:
Rukovalac podataka, na osnovu izjave prikuplja, obrađuje i koristi sledeće kategorije ličnih podataka o ličnosti:
1. imi i prezime
2. broj mobilnog telefona
3. adresa elektronske pošte (e-mail adresa) ...
Upisivanjem podataka na obrazac, Licu daje saglasnost Rukovalcu da upisane podatke prikuplja, obrađuje i koristi za svrhu navedenu u Obaveštenju i izjavi, a u skladu sa Zakonom o zaštiti podataka o ličnosti.

4. Pravni osnov podataka o ličnosti u svrhu realizacije Programa Lojalnosti, Rukovalac: da prikuplja, obrađuje i koristi sve podatke o ličnosti Licu u skladu sa Zakonom o zaštiti podataka o ličnosti i na osnovu saglasnosti Licu (Član 12. stav 1. tačka 1) koji Licu daje Rukovalac potpisom na licu. Podaci o ličnosti prikupljaju, obrađuje i koristi se u cilju:
- ostvarenja Programa Lojalnosti putem marketinških aktivnosti, uključujući direktni marketing i profilisanje;
- održanja i pružanja usluga koje odgovaraju konkretnim potrebama Licu na koje se podaci odnose, kao i u cilju uspešnijeg odnosa između Licu i Rukovalca podataka.

Obrada i obrada podataka o ličnosti je neophodna uslov za realizaciju Programa Lojalnosti, te je Licu niče da pruži podatke o svojoj ličnosti samo ukoliko želi da bude uključeno u Program Lojalnosti.

5. Rukovalac podataka o ličnosti
Rukovalac podataka o ličnosti koji su prikupljeni u cilju realizacije Programa Lojalnosti, odnosno svi dok je Licu na koje se podaci odnose uključeno u realizaciju Programa Lojalnosti, oim u slučajevima kada je Rukovalac podataka u obradi ili podatke Licu i licu obradu Programa Lojalnosti u skladu sa zakonom kojima se uređuje neobnovljive.

Podaci o ličnosti koji se obrađuju uključuju por osnovu pristanka Licu na koje se podaci odnose su obrađuju i u skladu sa svrhom zbog koje su prikupljeni, odnosno do opozita pristanka odnosno povlačenja saglasnosti od strane Licu na koje se podaci odnose i drugih slučajeva prestanka pravne osnovu za obradu podataka o ličnosti u skladu sa Zakonom.

6. Izmena podataka o ličnosti
Rukovalac podataka o ličnosti može izmisliti i drugi državljanin članica Konvencije Saveta Evrope o zaštiti licu u odnosa na automatski obradu ličnih podataka, odnosno u odnosa za koje od strane Evropske unije utvrdjeno da obuhvataju pravnenu osnovu za obradu u skladu sa Članom 64. Zakona o zaštiti podataka o ličnosti.

7. Prava Licu na koje se podaci odnose u vezi sa obradom podataka o ličnosti
Licu na koje se podaci odnose ima pravo na pristup podacima o ličnosti koji su obrađuju od strane Rukovalca podataka.
Licu na koje se podaci odnose ima pravo da zahteva ispravu, ažuriranje, brisanje podataka, kao i pristup i privremenu obnavljanje obrade na način propisan zakonom.

Licu na koje se podaci odnose ima pravo da u svakom trenutku podnese prigovor na obradu podataka o ličnosti koji se u obradu odnose.
Licu na koje se podaci odnose ima pravo da prenevanje podataka o ličnosti, odnosno pravo da podatke koji je prethodno dostavio Rukovalcu podataka licu izmisliti, u cilju pristupa drugim Rukovalcu podataka, kao i pravo da podaci o ličnosti licu neposredno prenesi drugom Rukovalcu podataka od strane Rukovalca podataka, ukoliko je u tome izdati izjava, u skladu sa pravom Rukovalca podataka, obavešten potrebom standard bezbednosti prenosa podataka o ličnosti.

Licu na koje se podaci odnose ima pravo da se obradi podaci o ličnosti bez odnosa ispravu, kao i da se neposredno podaci o ličnosti podnosa, uključujući obradu dodatne izjave, ukoliko je to potrebno skladu sa zakonom.

8. Prava na pristup/Povlačenje
Licu na koje se podaci odnose ima pravo da izmisliti pristup Rukovalcu podataka (Povlačenje za informaciju od javnog značaja i zaštita podataka o ličnosti, www.ovpovereci.rs) na obradu svojih podataka o ličnosti od strane Rukovalca podataka, ako smatra da je obrada podataka o ličnosti licu nezadovoljavajuća u odnosa odnosa Zakona o zaštiti podataka o ličnosti, u skladu sa Članom 62. tog Zakona. Povlačenje pristupa Povlačenje u odnosa na pravo drug licu da potvrdi druge podatke upravu ili nadležne zaštite.

10. Slabaša davanja saglasnosti i moguće posledice nedavanja saglasnosti za obradu podataka o ličnosti
Davanje saglasnosti za obradu podataka o ličnosti je dobrovoljno i zasnovano na slobodnoj i bez pritiska licu koji Licu na koje se podaci odnose, i to putem savetnog postupanja izjave.

11. Postupanje automatizovanog donošenja odluka, uključujući profilisanje
U okviru realizacije Programa Lojalnosti Rukovalac podataka primenjuje tehnike licu, polju automatizovanog i automatizovanog donošenja odluka, uključujući i profilisanje, u cilju održanja i pružanja usluga koje odgovaraju konkretnim potrebama Licu na koje se podaci odnose, kao i u cilju ostvarenja što većih pogodnosti (benefita) Licu na koje se podaci odnose u skladu u Programu Lojalnosti, koji licu licu mogu doneti posebne pogodnosti (benefita), uključujući i finansiranje (popusti, bonusi, paketi i sl) koji su Licu na koje se podaci odnose odnosa u licu licu licu, odnosno kupovni robu iz asortimana Rukovalca.

Rukovalac podataka odgovarajuće informacije, tehničke i korisničke mere licu iz zaštite licu podataka o ličnosti Licu na koje se podaci o ličnosti odnose, u primenu standarda na polju obaveštenja licu i ostvarenja saglasnosti podataka. Podatke o ličnosti Rukovalac licu kao povlašćene informacije.

DIMENSION OF ASSEMBLED APPLICATION FORM		DIMENSION OF PREPARATION WITHOUT BLEED		Bleed
width	height	width	height	
210 mm	297 mm	210 mm	297 mm	It is necessary to leave 3 mm ON ALL SIDES

CHAPTER 2

INSTRUCTIONS FOR PRODUCING FILES



2.1 BASIC REQUIREMENT

2.1.1 General

Preparation needs to be in CMYK colour mode so that the printing file can be used.

File must be prepared following the dimensions set.

All linked images within the working file must be **EMBEDDED**.

2.1.2 Colors and objects

Color values and vector objects must be prepared in CMYK color palette.

Black needs to be from carbon only (C:0% M:0% Y:0% **K:100%**).

Grey should also be from pure carbon in order to get pure grey.

Bitmap objects should be prepared at 300dpi in .JPG format.

2.1.3 Personalisation

Personalisation elements, including bar codes, signature strip and other, should be prepared in the form of vector object.

Text personalisation

We need to convert the whole text that does not need to be personalised into curves (make it unchangeable and uneditable and then when opened on some other computer, it will not require fonts).

Sending the font is obligatory for the text that is personalised.

We convert fonts into curves by clicking on the text (select/object/all text objects if we want to mark the whole text), then type/create outlines(ctrl+shift+O).

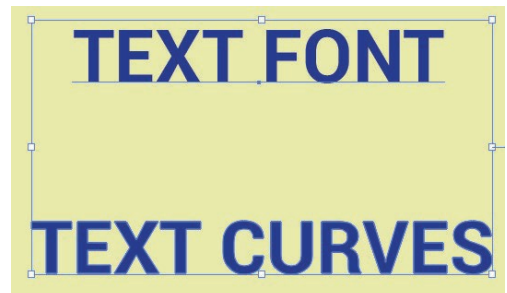

The example of the text preview in fonts and curves.

2.2 SETTING-UP THE CONTENT

2.2.1 Bleed

Graphic elements must be positioned up to the overhang line.

 WRONG

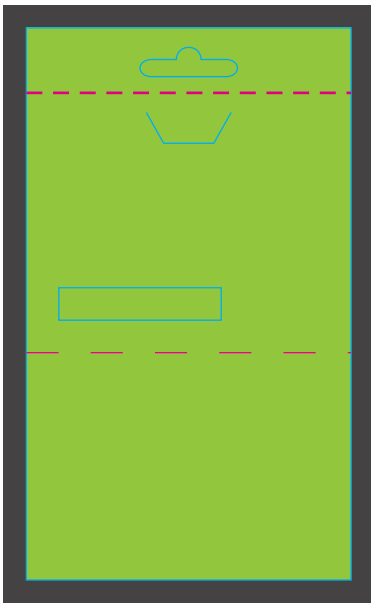

 CORRECT

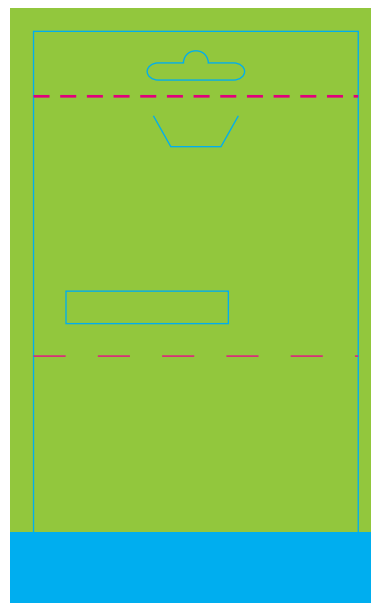
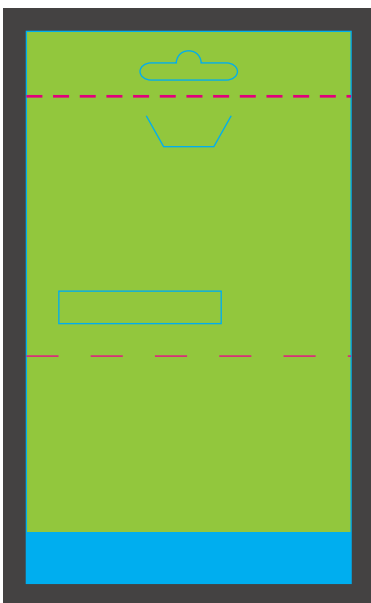
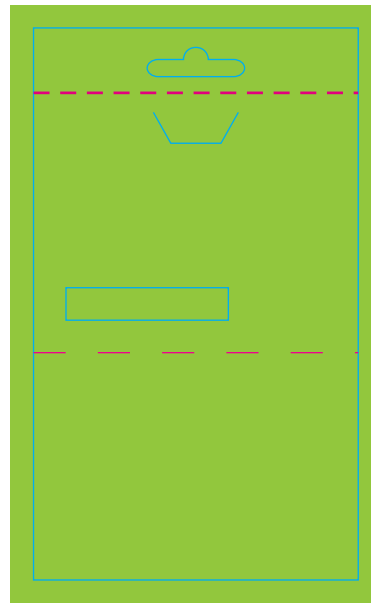

2.2 SETTING-UP THE CONTENT

2.2.2 Safe zone

To prevent graphic elements from getting to the cutting line, it is very important to position them within **safe zone**. Safe zone is 1.5mm from the cutting line.

Images need to be embedded when implementing them within your design. You can do it in Adobe *illustrator* by clicking the **'Embed'** button in the upper left corner of the *illustrator* window..

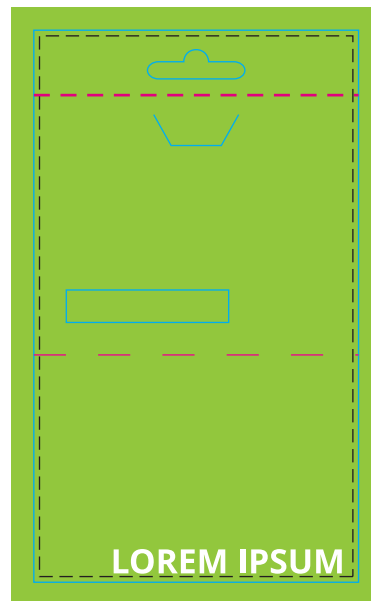
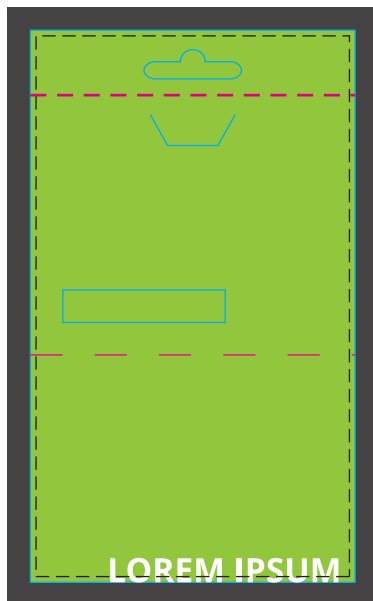

2.2 SETTING-UP THE CONTENT

2.2.3 Preparation of background for perforation

Colors or elements in the background should not have sharp gradation with perforation or creasing but we recommend a single transition in gradient way, one-color background or graphics/image whose elements do not necessarily reach perforation or creasing line.

 NOT RECOMMENDED

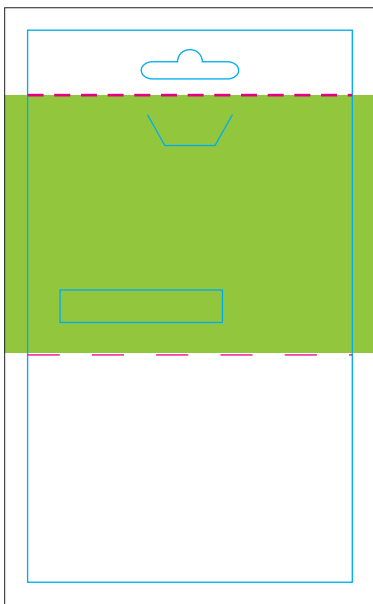

 RECOMMENDED

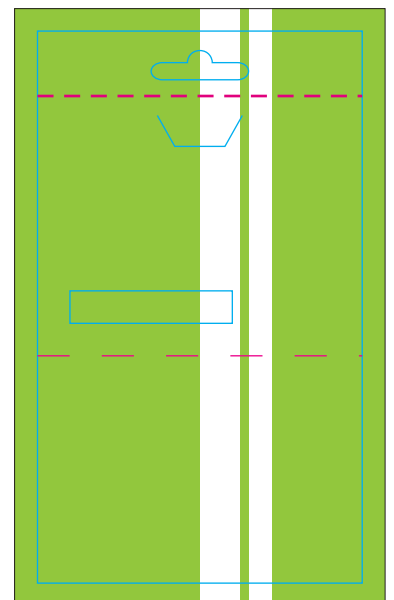
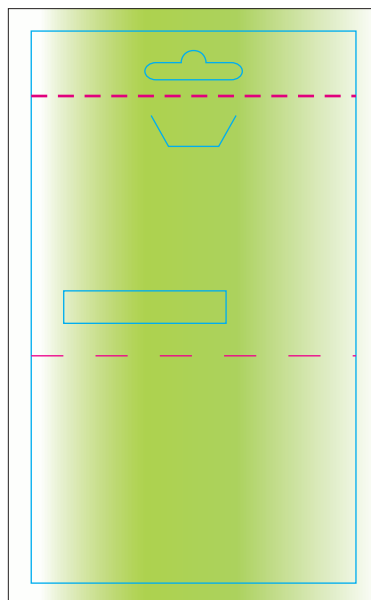
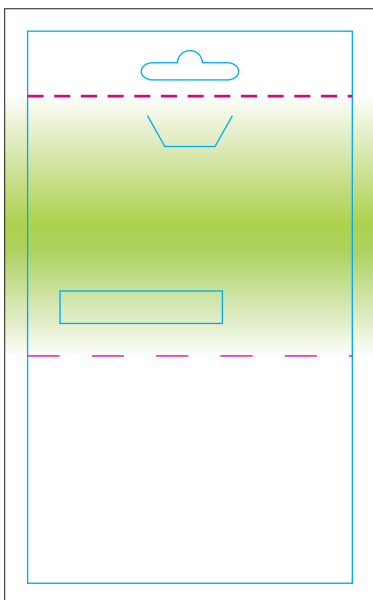

CHAPTER 3

RECOMMENDATIONS



3.1 SOFTWARE

3.1.1 Software selection

We recommend using softwares by the company **Adobe Systems Incorporated** to achieve the easiset compatibility with computing standards.

Each software has its own specific role and does not necessarily give the best solution for printing which also includes the software by the company **Adobe**.

For instance, it is usually mistakenly believed that one of **Adobe Photoshop** functions is saving in PDF format keeping vector layers. What is actually extracted is not a vector object with typical characteristics for this class but raster layers of bitmaps which makes a different type of object.

That's why efficient use of this object is not possible, so the printing quality could be lower than expected.

This is exactly the reason why our choice is Adobe Illustrator which contains original vector objects and exports it in PDF in accordance with the standards.

3.1.2 Effects and filters

Tools such as filters, shades, gradients etc. may vary through different versions of the software used. That is the reason why we strongly recommend a detailed checking of the preview we send you for confirmation as well as the sample if we deliver it to you.

3.2 COLORS

3.2.1 Overprint

Overprint option includes values of the covering colors. Covering colour means rewriting or reprinting over other colours.

A common mistake in preparation for printing is when black is not set to overprint but it covers them.

The most common problem in that case is black letters which are then very difficult to fit into printing. The most common lapse happening is photoshop files because it is not set to overprint black.

OVERPRINT option is not recommended for the type of printing we do.

3.3 TYPES OF FILES

Files we recommend:

- Ai
- PDF
- CDR
- EPS
- SVG

Files we do not recommend:

Partial or complete inability to correct or adapt to the type of printing.

- PSD
- JPG

CHAPTER 4

ADDITIONAL INFORMATION



4.1 SCOPE OF RESPONSIBILITY

Bear in mind that the company **Cards Print** is solely responsible for technical part of printing and shall not bear liability for the file client sends, the way it was created and the extent the abovementioned files match our specification.

Not following requests and recommendations listed in this specification can make the file unusable or cause poorer quality than expected. In case a client wants to change the file, our design team estimates the file and informs the client of the corrections requested that can be made.

4.2 CHECKLIST

- Correct file (Vector format)
- Vector elements within the file
- Following safe zone
- Leaving bleed
- Dimensions in accordance with specification
- Colors is CMYK
- Text in curves
- Fonts for personalisation
- Images Embedded within the file (JPG, 300dpi)
- Effects, filters and overprint
- Background with perforation